

Dura-Bond[®]

Valve seat inserts

Technical Information and
Installation Instructions

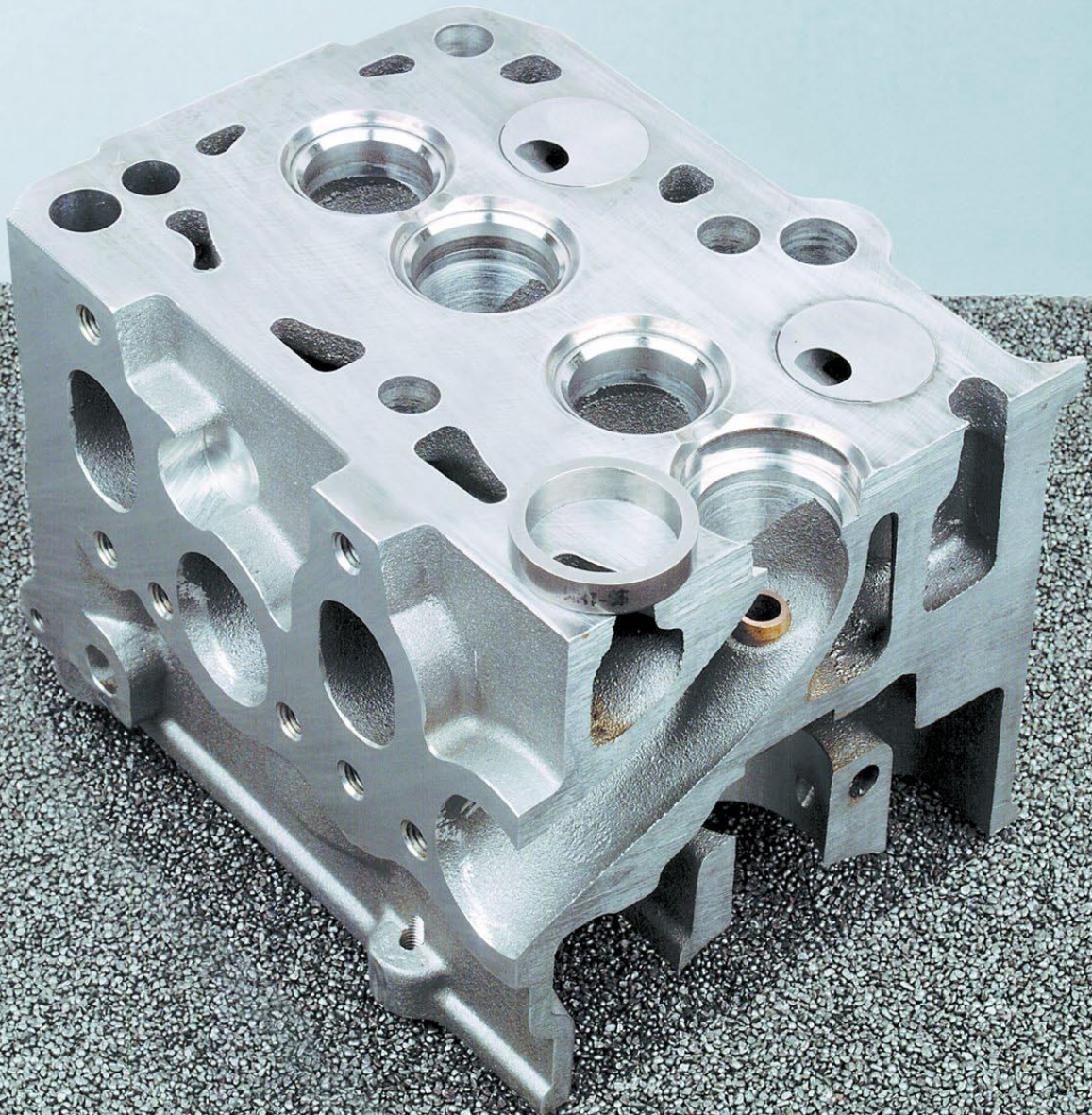

Index

Chapter 1: Introduction

- 1.1 Valve seat installation
- 1.2 Machining practices

Chapter 2: Cutting valve seat inserts and counter bores

- 2.1 Removal of valve seats and cutting of seat pocket counter bores

Chapter 3: Installation

- 3.1 Inserting the valve seats
- 3.2 Cutting the seating surface
- 3.3 Using a cutting machine
- 3.4 Using a grinding machine
- 3.5 Checking the final product

Chapter 4: Dura-Bond valve seat inserts

- 4.1 Valve seat inserts Materials
- 4.2 30000 / 70000 Series
- 4.3 Overview

Chapter 1: Introduction

1.1 Valve seat installation

Valve seat installation and refitting is only one of many operations necessary for the professional rebuilding or reconditioning of a cylinder head. Successful cylinder head remanufacturing requires that these reconditioning operations be done in the correct sequence.

Valve seat installation and refitting can only be successfully accomplished after the following operations have been completed.

- Through cleaning, inspection and any failure analysis
- Measure and record each assembled valve stem height and valve head protrusion
- Straightening of the cylinder head and milling/grinding of the firing deck and all other mating surfaces
- All valve guides must be renewed or refitted and be within original factory specifications

The cylinder head must be dimen-

sionally and geometrically within original factory specifications. The cylinder head thickness, valve guide clearances, concentricity, and perpendicularity must be correct. There should be no warping, twisting, or any type of misalignment of any part of the cylinder head.

Sometimes you may lightly touch up the valve face and valve seat mating surface without putting the valve geometry out of factory specification but most of the modern multi-valve aluminum cylinder heads will require new inserts be installed to maintain correct valve train geometry.

Only new valves or valves which have been reconditioned and are within original factory specification must be used. All valve springs must be inspected and must meet all original factory specifications or be replaced.

As it relates to valve seats, there are three types of cylinder heads:

- Cast iron cylinder heads with removable valve seat inserts
- Cast iron cylinder heads with integral hardened valve seat areas
- Aluminum cylinder heads with removable valve seat inserts

You must replace the old valve seat insert or refit the integral hardened valve seat area with a new valve seat insert if:

- The cylinder head required straightening before resurfacing.
- Any welding had to be done on the cylinder head.
- The cylinder head is aluminum and was cleaned in a heating oven.
- The valve seating (mating) surface has receded beyond factory specifications.
- The valve seating (mating) surface is too wide and recutting or regrinding would lower the seat beyond factory specifications.
- The integral seat of a cast iron head has been ground before. (The depth of the hardened cylinder head material used for the seating area will be too shallow to allow a second grinding)
- There is any evidence that the valve seat insert is loose in the counter bore pocket, or does not have adequate interference fit.
- There is any evidence of corrosion of the cylinder head material around the outside diameter of the valve seat insert.
- There is any evidence that the seat has any cracking, burning, pitting or fissures.
- The fuel type being used is going to be changed. This will require a higher duty range valve seat for better durability.

1.2 Machining practices

Although many factors contribute to the successful machining of valve seats. Here are several key conditions that are required to achieve good results.

- By far the most important is to have properly sharpened tools and properly dressed grinding stones.
- Keep your tooling setup as "short and tight" as possible to assure rigidity (Picture 1). The less deflection in the tooling the more accurate the dimensions of the cut and the greater concentricity.
- Keep your clamping arms and fixtures in good repair for correct gripping.
- Make sure not to distort or put a twist into the cylinder head when clamping to a fixed rail cylinder head holding fixture (Picture 2).
- Use the correct size pilots, which must be straight.
- Use the correct spindle speeds and feeds.

Picture 1



Picture 2

Chapter 2: Cutting valve seat inserts and counter bores

2.1 Removal of valve seats and cutting of seat pocket counter bores

Replacing valve seats in heads with removable seat inserts can be done in several ways, but the method we recommend is to use a cutter slightly smaller than the outside diameter of the existing valve seat insert and cut the old seat out (Picture 3). Stop cutting just as the old seat insert begins to rotate. The thin wall of the old valve seat insert can now be easily removed (Picture 4).

Some machinist will install a new insert in the existing seat pocket without recutting the counter bore. Although this method can be used on some large cast iron cylinder heads which are thick walled, it is not a recommended procedure for most automotive or "light pattern" cylinder heads. It is much better to cut a new seat insert counter bore for better valve life and valve

seat insert retention in the cylinder head (Picture 5). This will also insure concentricity and perpendicularity with the valve guide and will provide a fresh metal surface for better heat transfer (see our recommended interference fit chart for the correct outside diameter).

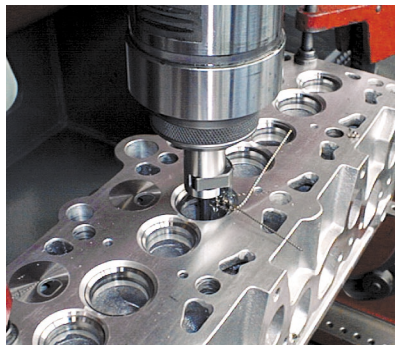

Picture 3 - Cutting valve seat inserts



Picture 4 - Removing the thin wall of the old valve seat insert



Picture 5 - Cutting the counter bore

When machining the seat pocket counter bore in a **cast iron cylinder head** we recommend a cutting

speed of **100 to 250 RPM** with no cutting oil. When cutting a seat pocket counter bore in **aluminum**

cylinder heads we recommend using a cutting oil and a spindle speed of **400 to 600 RPM**.

DuraBond recommends the following press fittings:

Outer diameter valve seats inserts [inch]	[mm]	Material cylinder head cast iron [inch]	[mm]	Material cylinder head aluminium [inch]	[mm]
0.7874 - 1.1811	20 - 30	0.0031	0,08	0.0047	0,12
1.1811 - 1.5748	30 - 40	0.0043	0,11	0.0059	0,15
1.5748 - 1.9685	40 - 50	0.0051	0,13	0.0071	0,18
1.9685 - 2.3622	50 - 60	0.0063	0,16	0.0079	0,20
2.3622 - 2.7559	60 - 70	0.0071	0,18	0.0087	0,22

Replacing valve seats in cylinder heads with integral seats will require a new seat pocket counter bore to be cut. The approximate outside dia-

meter for the replacement seat is .100" (2,5 mm) larger than the valve head diameter. The inside diameter of the replacement seat is approximate-

ly .100" (2,5 mm) smaller than the valve head diameter. The depth is usually .188" to .250" (4,7 - 6,4 mm). These sizes are guidelines only.

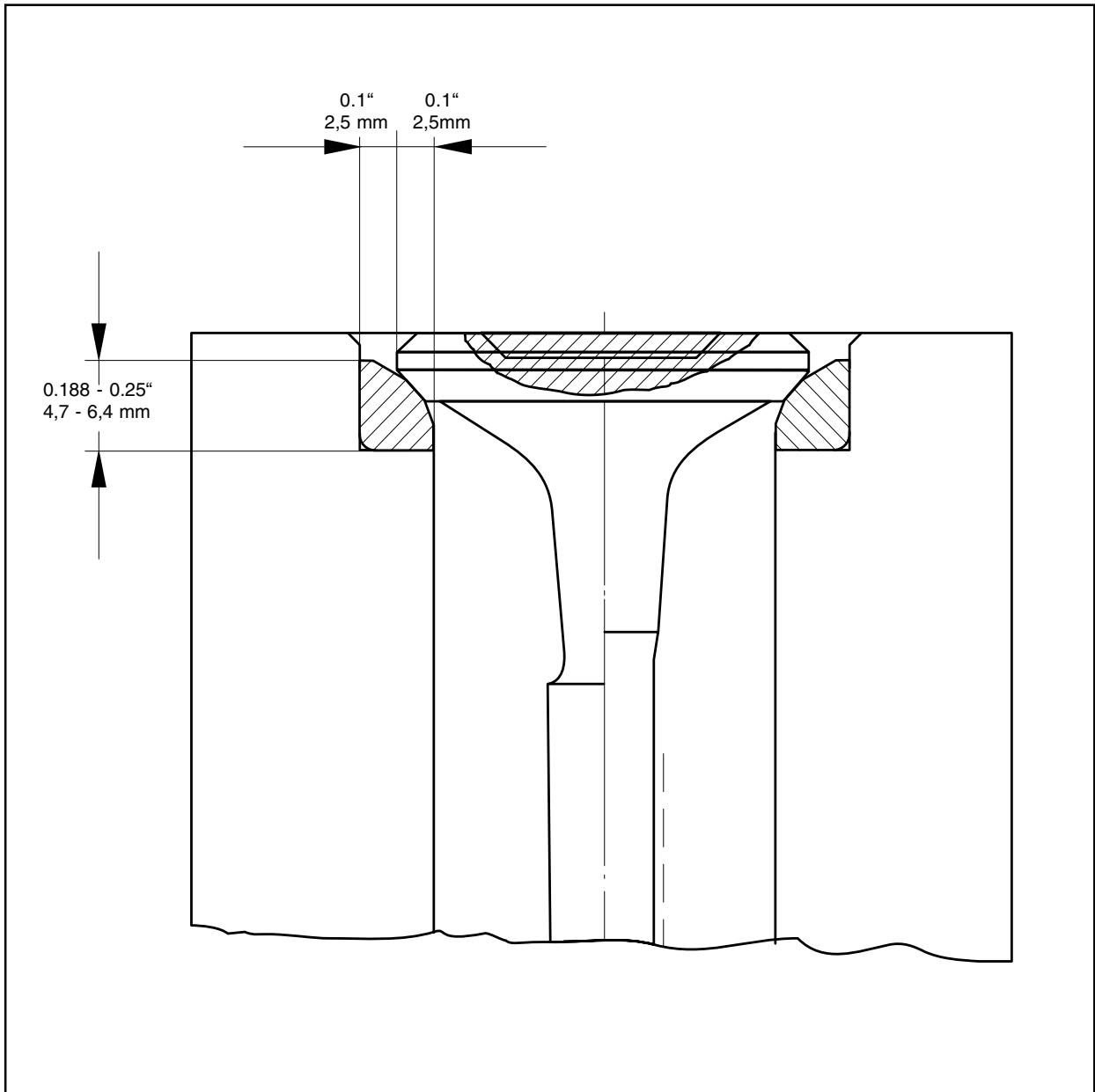

Many of the newer cylinders do not have the room to install seats with OD's larger than the OD of the valve (see our recommended interference fit chart for the correct outside diameter).

All counter bores must be concentric with the valve guide, have a straight wall, flat bottom and be within .0005" (0,013 mm) of correct size and be round.

Chapter 3: Installation

3.1 Inserting the valve seats

Before pressing in the new valve seat insert please be sure:

- Verify that the valve seat dimensional measurements are correct
- Verify the counter bore measurements are correct
- Make sure there are no chips or debris in the counter bore
- Use a seat installation tool to insure that the valve seat is inserted squarely into the counter bore pocket (Picture 6).
- Use a flat and square seat driver tool whose size is just slightly smaller than the outside diameter of the valve seat insert (Picture 7).
- Use a correct size pilot for the valve guide, when using this valve seat driving tool.

For Dura-Bond valve seat inserts:

- **Insert the valve seat with the radius side down.**
- **Because of the smooth radius on the bottom outside edge and the compressive “spring action” of the material, shrinking of the seat using liquid nitrogen and heating the cylinder head is not necessary prior to insertion the cylinder head.**

Picture 7



Picture 6

Less force required - less chance of damaging seat counter bore.

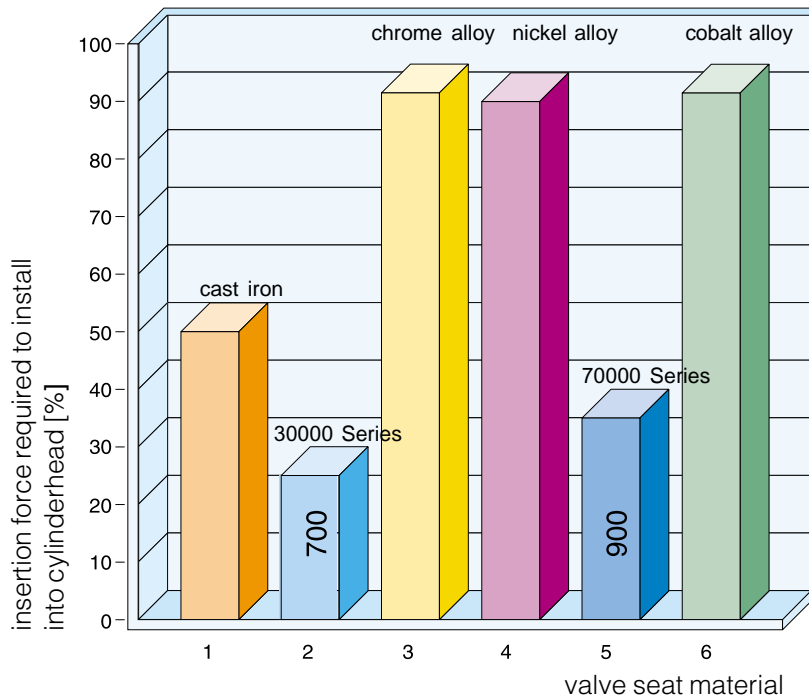

3.2 Cutting the seating surface

Check the engine specification manual for the correct assembled valve height, valve protrusion, seat angles, seat widths and any other special seat requirements. These factory specifications are important to maintain the correct valve lash,

compression ratios, clearances between valves and pistons, and the general overall valve train geometry. Machining and assembling the cylinder head to the original manufacturer's specifications is critical for the correct operation of the engine.

3.3 Using a cutting machine (Picture 8)

- Select a cutter profile matching the original factory valve seat. The top and bottom relief angles, and the seating surface width and angle must match the design called for by the original engine manufacture for the valve train geometry to be correct.
- Select the type and grade of carbide best suited for the hardness of the valve seat being machined.
- Make sure that the tool is sharp and has the correct rake angles and relief angles.
- A 5-degree cutting rake angle with an 11-degree relief or clearance angle is generally found to be best for valve seats up to 1.250" (31,8 mm) in diameter.
- A 3-degree cutting rake angle with a 7-degree relief or clearance angle is generally found to be best for cutting valve seats larger than 1.250" (31,8 mm) in diameter.
- Select the correct spindle speed for the type of seat being cut.
- A spindle speed of 150 to 450 RPM is generally a good speed for cutting the valve seat insert less than 1.500" (38,0 mm) in diameter.
- A spindle speed of 100 to 250 RPM works best for seats larger than 1.500" (38,0 mm) in diameter.
- **Dura-Bond finds that most people who have the drill press style of machine, like the 50 - 100 RPM**
- Set the cutter bit to the correct size for the valve being used according to the factory repair manual.
- Cut the seat depth to match the correct assembled valve height.

Outer Diameter valve seat insert [inch]	[mm]	Tool		RPM [1/min]
		relief angle	cutting angle	
< 1.250	< 31,8	11°	5°	150 - 450
> 1.250	> 31,8	7°	3°	150 - 450
< 1.500	< 38,0	7°	3°	150 - 450
> 1.500	> 38,0	7°	3°	100 - 250



Picture 8

3.4 Using a grinding machine

- Select the correct size of stone for the valve being used.
- Select the correct type of stone for the hardness level of valve seat.
- Dress the stones as needed to the angles specified in the repair manual.
- Grind the seating angle first
- Grind the top relief angle to adjust seat height
- Grind the bottom relief to adjust the seat width.

Adjustments to these grinds will be necessary to achieve the correct assembled valve height and seat width.

In general, if no factory specifications are available, remember to keep the valve face and valve seat contact area to the outer limits of the valve head diameter. Depending on the valve head diameter this contact area will be .015" to .030" (0,4 – 0,8 mm) in from the outside diameter of the valve head. If the seating contact area is too close to the valve stem you will impede the gas flows and build up heat on the exhaust side and possibly restricted power due to less air and fuel getting into the combustion chamber on the intake side. You will get better heat transfer away from the exhaust valve and into the

water jacket if you keep the contact area to the outside diameter of the valve head. But you must not take it to the extreme outside diameter or you will "burn" the valve and seat prematurely, because there will be too much heat concentrated at the very edge of the valve.

Also, in general, for valve seats in the 1.375" to 2.125" (35,0–54,0 mm) diameter range, if no specific factory specifications are available, a general guideline is to make the valve face to valve seat contact area width between .040"-.060" (1,0 – 1,5 mm) for the intake and .060"-.080" (1,5 – 2,0 mm) for the exhaust. For valve seats smaller than 1.250" (31,8 mm) the seat widths will be reduced by one half the values listed above. For engines using LPG, the exhaust seating width should be .100" (2,5 mm).

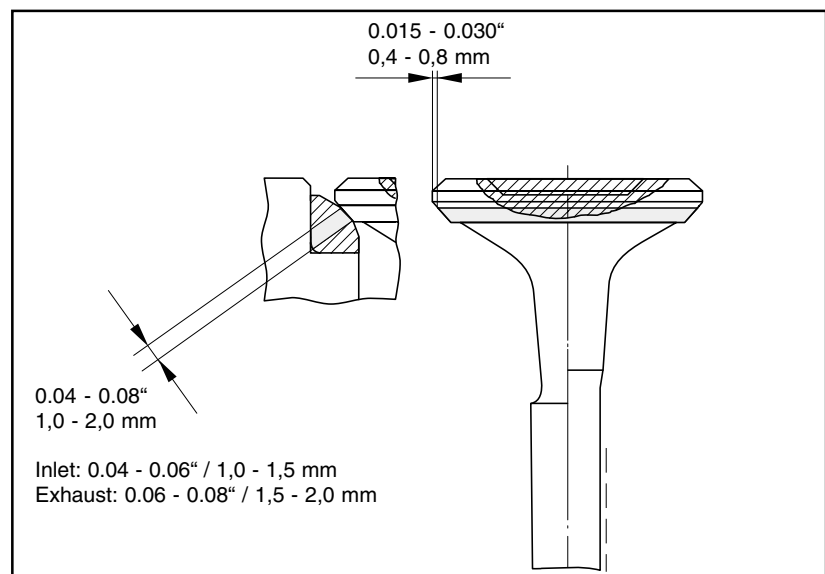

Wider seating widths will give a greater area of surface contact which will give better cooling rates but the larger contact area will reduce the pounds per square inch sealing pressure, so too large of a contact area will cause seats to

"burn" due to gas leakage. Too thin an area will cause high mechanical abrasion forces and high operating temperatures and will "wear" the seating area faster than normal.

3.5 Checking the final product

- Check the sealing by using a vacuum check
- Check the seating position by using Prussian blue on the valve and seat
- Check for the correct assembled valve stem height and valve head protrusion

Chapter 4: Dura-Bond® Valve Seat Inserts

4.1 Valve seat inserts

Materials

Modern engines put much higher levels of thermal and mechanical stress on valve seat inserts. To handle the more severe conditions within these new generations of engines, the OE-Manufacture is equipping them with high tech sintered valve seat inserts. The normal cast iron valve seat will not adequately withstand the demands of this new engine environment.

This is the reason why Dura-Bond offers high tech sintered valve seats in two specifications to be used for the complete range of today's engines and the engines of the past and of the future.

4.2 30000 / 70000 Series

• 30000 (Gold) Series High Machinability

This sintered insert offers a blend of finely dispersed tungsten carbide residing in a matrix of tempered tool steel and special alloy iron particles. With this blend, the 30000 series represents a superb combination of good hardness and good

machinability. The machinability is comparable to cast iron, and this 30000 series shows good wear and heat resistance.

This very machinable material is designed for naturally aspirated and turbocharged engines in the light to upper duty range.

• 70000 (Diamond) Series High Temperature Resistance

This specification has very high heat resistance which will remain even at very high temperatures. The sintered insert is made out of a high speed tool steel (tungsten carbide). This insert also has ceramic like characteristics, which give it very high temperature resistance. It has special additives blended into the matrix which impart high temperature lubricant properties to the valve seat. This solid lubricant enables this material to be used in dry fuel applications, such as propane, LPG and natural gas. They prevent the microwelding of the valve seat material to the valve face.

This eliminates the primary cause of valve seat erosion and failure. This very high heat and wear resistant seat is designed for propane, LPG and natural gas engines, as well as for high performance engines, heavy duty and extremely duty applications.

4.3 Overview

	30000 Series (High Machinability)	70000 Series (High Temperature Resistance)
Fuel type	petrol (unleaded), diesel	propane, LPG, natural gas, petrol (unleaded), diesel
Cylinder head Material	aluminium, cast iron	aluminium, cast iron
Applications	turbocharged engines, aspirated engines, lower to upper duty range	heavy and extreme duty range high performance engines, all gas engines (propane, LPG)

Dimensional specifications must be evaluated in order to assure correct selection of valve seat whenever engine parts are being selected. Heavy duty or extreme service applications should be considered to

assure that the individual engine rebuilder's standards are met and are the responsibility of rebuilder to determine suitability.