

The 4/4 Morgan



INSTRUCTION BOOK

MORGAN MOTOR CO. LTD.
MALVERN LINK
WORCS.

TELEGRAMS:
MORGAN MOTORS, MALVERN

TELEPHONE:
MALVERN 106

PRICE
7/6

CONTENTS

	<i>Page</i>
CHAPTER I	
New Engines. Starting and Driving Formalities. Method of Gear Changing. Gear Changing up and down. Use of Clutch, etc.	5
CHAPTER II	
Lubrication. List of recommendations. Points to lubricate. Chassis diagram	9
CHAPTER III	
Engine Maintenance—Lubrication—Ignition—Dynamo and Starter—Valve Clearances—Valve Timing—Ignition Timing—Decarbonizing and Valve Grinding—Removing Cylinder Head—Removing Valves—Grinding in Valves—Re-assembling—Sparking Plugs—Timing Chain—Timing Cover—Carburettor—Petrol Pump	11
CHAPTER IV	
Clutch—Gearbox—Transmission Shaft—Rear Axle—Differential	30
CHAPTER V	
Steering—Front and Rear Suspension—Shock Absorbers	32
CHAPTER VI	
Brakes—Brake Shoe Expander—Brake Shoe Adjuster—Balance—Re-lining	36
CHAPTER VII	
Jacking System—Wheels and Tyres—Tyre Pressures	39
CHAPTER VIII	
General—Hood—Side Curtains—Repairs	40

INDEX

	<i>Page</i>
Brakes	36
Carburettor	25
Chassis Diagram	22-23
Clutch	30
Decarbonizing	14
Differential	31
Gearbox	30
Gear Changing	6
Hood	40
Hubs	37
Ignition Timing	13
Jacking System	39
Lubrication Chart	22-23
" Engine	11 & 18
" Recommendations	10
" Location of Grease Nipples	9
Oil Pressure	12
Petrol Pump	28
Rear Axle	31
Shock Absorbers—Front	32
" " —Rear	35
Side Curtains	40
Sparking Plugs	21
Springs—Front	32
" —Rear	35
Starting Formalities	6
Steering	32
Suspension—Front	32
" —Rear	34
Tappets	20
Timing—Ignition	13 & 20
" —Valves	12
" —Chain	20
Transmission Shaft	30
Tyre Inflation Pressures	39
Valve Clearances	12
Wheels—Alignment	39

FOREWORD

The Morgan 4/4 has been designed to provide a car with a good performance, comfortable and easy to handle and handsome in appearance, at the same time simple to maintain and economical to run.

Each car is carefully built and tested, but the continued satisfaction of the owner is largely in his own hands. The best of cars will not run well unless careful attention is paid to their upkeep.

For this reason we are issuing this Instruction Book, hoping that it will be of interest and use to owners.

There are three points we wish Morgan Users to bear in mind.

1. The importance of regular lubrication, which in the Morgan is a very simple matter.
2. The necessity of keeping nuts, bolts and screws tight. The pleasure of driving a car is often spoiled by noises and rattles, which could easily be avoided if loose parts were attended to at once.
3. The importance of seeing that the brakes are adjusted properly and in good working order.

We do not advise alterations or adjustments unless absolutely necessary, and then it will be better to get our advice or apply to the makers of the various components used. Advice will be given if it is asked for and stamped envelope enclosed.

Do not hesitate to write to us if you are in any difficulty ; we will do our utmost to help you.

DESCRIPTION OF CAR

ENGINE.		CARBURETTOR.	
Bore . . .	63.5 mm.	Type . . .	Solex Down Draught
Stroke . . .	100.0 mm.	Main Jet . . .	No. 125
Capacity . . .	1,267 c.c.	Air Jet . . .	No. 45
B.H.P. . . .	40 at 4,300 r.p.m.	Starter Jet . . .	No. 100
Comp. Ratio . . .	7—1	Pilot Jet . . .	No. 45
Firing Order . . .	1, 3, 4, 2	Correction Jet . . .	No. 170

DIMENSIONS.	2-Seater.	4-Seater.	Coupe.
Wheelbase . . .	7' 8"	7' 8"	7' 8"
Track . . .	3' 9"	3' 9"	3' 9"
O/all Length . . .	11' 4"	11' 7"	11' 7½"
O/all Width . . .	4' 7"	4' 7"	4' 7"
O/all Height. Closed . . .	4' 4½"	4' 6½"	4' 3"
Ground Clearance . . .	6"	6"	6"
Turning Circle . . .	33' 0"	33' 0"	33' 0"
Tyre Sizes . . .	4.50—17	4.50—17	5.00—16
Weight Dry . . .	14½ cwts.	14½ cwts.	15 cwts.

GENERAL.	
Rear Axle Ratio . . .	4.72—1.
Gear Ratios . . .	Top, 4.72—1 ; 3rd, 6.70—1 ; 2nd, 11.42—1 ; 1st, 16.14—1 ; Reverse, 21.33—1.
Suspension . . .	Front, Independent, Coil Springs, with Newton Hydraulic Dampers. Rear, Semi-elliptic with Andre Dampers.
Cooling . . .	Thermo-Syphon.
Radiator Capacity . . .	2 Gallons.
Clutch . . .	Borg and Beck, Single Dry Plate.
Oil Capacity . . .	Sump 11 pints, Gear Box 2 pints, Rear Axle 2 pints.
Fuel Capacity . . .	9 Gallons.
Brakes . . .	Girling Mechanical. Coupled to foot pedal. Racing type hand lever to rear only.
Valve Timing . . .	Inlet opens 10° before T.D.C. Inlet closes 50° after B.D.C. Exhaust opens 50° before B.D.C. Exhaust closes 10° after T.D.C.

NEW ENGINES.

When the car is new the engine may seem to be somewhat lacking in power due to the bearing surfaces not having become fully bedded down. This will continue for the first 200/300 miles, during which time the engine will, with proper use, gradually become run-in.

The power will then improve, as the car is used, for the first 1,000 miles and this will be accompanied by a corresponding improvement in petrol consumption.

It is not advisable to drive a new car fast, or to run the engine at a high speed in the lower gears. The good and lasting bearing surfaces obtainable by careful running in, are well worth while the patience required to drive the car only at moderate speeds during the early stages of its life.

While it is not possible to lay down hard and fast rules on the subject of maximum speeds during the running in period, the following table will serve as a guide to the permissible speeds in the various gears during this period.

Gear	Speed
Top . . .	40 m.p.h.
3rd . . .	30 m.p.h.
2nd . . .	20 m.p.h.
1st . . .	10 m.p.h.

It is emphasized that this table is not intended as a hard and fast ruling on this matter, but should be regarded as a guide only. There are two main points which should be watched in this connection, first, the engine should on no account be allowed to "labour" during the period of running in, and judicious use of the gear box should be made, to ensure that the engine is kept turning over freely and easily. Far less harm would be caused by allowing the car to climb an incline at say 30/35 m.p.h. on third gear, if at this speed the engine is running freely, than by making the car climb the same incline at 20/25 m.p.h. on top gear, and thereby causing the engine to pull heavily or "slog".

Secondly, the amount of work given to the car to perform should be progressively increased over the first 1,000 miles.

It would be a waste of time to run the car at a steady 30 m.p.h. for the first 1,000 miles, thinking that at the end of this period the car would be fully run-in. In actual fact, if this procedure were adopted, the car would be little more run-in than when it left the factory, and it is quite possible that a sudden increase in speed or load, after such a period, would have disastrous results.

It will be appreciated therefore that during the running-in period, the aim should be to progressively increase both the speed and the load condition, over the whole of the period, so that at the end, the working parts of the engine, and of the car as a whole, are fully

bedded down, and the car thus be in a condition to give of its best, and continue to do so over the whole of its life.

When the car is new, the owner may with advantage add $1\frac{1}{2}\%$ of engine oil ($\frac{1}{2}$ pint to 2 galls.) to the petrol, for the first 250 miles.

Alternatively, we have found the use of an upper cylinder lubricant to be of advantage, particularly in new engines, and recommend the use of such a lubricant until the engine is fully run-in. The lubricant should be mixed with the petrol in accordance with the instructions given on the container. Such lubricants may be used with advantage throughout the life of the car, and especially during wintry weather.

Running-in compounds containing colloidal graphite, prepared in a form suitable for addition to the engine oil are also available and will be found to materially assist and improve the bedding in of the engine bearings, and are to be recommended.

STARTING AND DRIVING FORMALITIES.

Before starting the engine it is advisable for the new driver to become familiar with the various controls, and it is usual for the dealer supplying the car to explain these details fully, but for the benefit of those who are not altogether clear no harm can result in repeating the instructions here.

Before attempting to start the engine it should be ascertained that the gear lever is in the neutral or free engine position. The various gear positions are clearly marked on the gear lever knob, but for easy reference of the reader they are shown here in Fig. 1.



Fig. 1

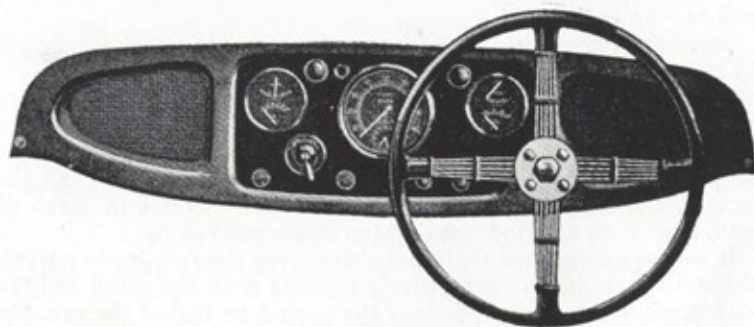

Fig. 2

Fig. 2 on page 6 shows the layout of the instruments and the several control knobs referred to in the following remarks. When ready to start, turn the ignition key and switch on, when immediately the red warning light in the panel will appear. The light should remain while the car is stationary and the engine running slowly, but will disappear when first gear is engaged and the car gets under way. Having switched on, pull out the mixture knob on the left-hand side of the panel and afterwards pull the knob marked "starter," when the engine will commence running. Move off immediately and after say half a mile the "mixture" knob should be pushed back. Do not allow the knob to remain out after warming up, or too rich a mixture will result, which will cause the sparking plugs to become sooted and the engine to run imperfectly. It should be mentioned that the knob is provided to allow easy starting from cold, and after warming up there is no further necessity to use it. Apart from causing imperfect running, if allowed to remain out, it will have an adverse effect on petrol consumption. Its function is further described under the Chapter headed "Carburettor".

To move off, press the clutch pedal with the left foot and move the gear lever into first gear position. When the first gear is engaged, take off the hand brake, gently release the pressure on the pedal so that the car will move off smoothly. Sudden removal of the foot from the pedal will allow the clutch to engage too quickly, with the possibility of stalling the engine. At the same time accelerate gradually by slight pressure on the accelerator pedal. When a speed of 10/15 m.p.h. is attained, ease pressure on accelerator, press out clutch and bring the gear lever back into second gear position, afterwards allowing the clutch to re-engage and again accelerate. Adopt the same method when engaging third gear at say 25 m.p.h. and again at about 40 m.p.h., when fourth or top gear should be engaged. Control the speed of the car by applying or releasing pressure on the accelerator pedal. On reaching gradients, or when traffic conditions necessitate slowing down below 10-15 m.p.h., a lower gear should be engaged. The same method is employed as that already described, except that to engage the lower gears it is necessary to accelerate, between the process of de-clutching and engaging the lower gear. In changing down, the popular method is to double de-clutch, the sequence of which is to de-clutch, disengage gear, re-engage clutch, de-clutch again and engage the lower gear, finally re-engaging the clutch. The art of changing gear can more readily be attained by actual use and practice in preference to any written instructions that may be given. To slow down or stop, do not brake hard, but de-celerate well in advance of your objective, transfer right foot to brake pedal and bring the car gradually to a standstill, move the gear lever into the neutral position and apply

the hand brake. The red warning light will have re-appeared as a reminder that the ignition should be switched off.

To obviate the possibility of reverse gear being accidentally engaged when changing down, a suitable stop is provided in the gear box, and to engage the reverse gear the lever should be lifted slightly, thus allowing the selector forks to pass this stop.

To the initiated, the preceding remarks may appear superfluous, but to the new driver they may be a distinct advantage. The Chapters which follow, deal with maintenance and adjustment, and will be of benefit to both novice and expert alike.

Chapter II

LUBRICATION

This is one of the most important subjects in connection with the upkeep of the car, and careful attention to the following remarks and instructions will be amply repaid by the results obtained, and the utmost satisfaction from the Morgan 4/4 will result from the use of the lubricants specified.

A chassis lubrication Chart is included in the centre pages of this Instruction Book, and the recommended mileages at which lubrication should be carried out are indicated.

Grease nipples are located as follows (see Chassis diagram) :—

1 to each front sliding axle.

1 to each front brake cable.

1 behind Clutch housing (lubricates clutch thrust mechanism).

3 on pedal brackets and sleeve.

1 on front end of Propeller Shaft (access to this is through hole in shaft tunnel).

1 to each Universal Joint on the Propeller Shaft.

1 to Brake Cable from pedal to rear.

1 to each Rear Hub.

1 to each Rear Spring.

The two last mentioned nipples can only be seen when the rear spare wheel is removed.

In addition to the nipples mentioned, apply oil periodically to the ball joints of the steering drag link, brake yoke and pins, and balance lever pivot pins, engine control lever joints, etc. It is also advisable to apply a spot of oil occasionally to the threads of the wheel studs in order to prevent the nuts becoming rusted on.

The importance of frequent lubrication of the sliding axles cannot be too highly stressed. Never over-run the period given on the chassis diagram ; comfort is to a large extent dependent on the free working of these parts, and neglect will result in tightness, which not only makes the springing harsh, but results in excessive wear, necessitating renewals before it should be necessary.

MORGAN 4/4 RECOMMENDED LUBRICANTS

	ESSO	PRICE'S	WAKEFIELD	VACUUM	SHELL
ENGINE	Summer Winter	Energol S.A.E. 30 Energol SAE 20	Castrol XL Castrolite	Mobiloil A Mobiloil Arctic	Double Shell Single Shell
GEAR BOX	...	Energol SAE 90	Castrol XXL	Mobiloil A	Triple Shell
REAR AXLE	Summer Winter	Energol SAE 140 Energol SAE 140	Castrol D Castrol ST	Mobilube C Mobilube CW	Shell Spirax C Shell Spirax C
STEERING BOX	...	Energol SAE 140	Castrol D	Mobilube C	Shell Spirax C
WHEEL HUBS	...	Melmoline C	Castrol Heavy	Mobil Hub Grease	Shell Retinax RB
CHASSIS	...	Belmoline C	Castrol Medium	Mobilgrease MP	Shell Retinax CD
EXPOSED SPRINGS	...	Price's Penetrating Oil or Belmoline C	Castrol Penetrating Oil or Castrollease CL	Mobil Spring Oil or Mobilgrease No. 2	Shell Donax P or Shell Retinax CD
OIL CAN	...	Energol SAE 20	Castrolite	Mobiloil Arctic	Single Shell

10

Chapter III

ENGINE MAINTENANCE

LUBRICATION.

Check daily the oil level in the sump by withdrawing the dipstick and ensuring that the oil is at the correct level. The dipstick shows "high" and "low" levels and oil should lie between these two marks, preferably nearer the "high" level.

After the first 1,000 miles, and thereafter every 4,000 miles, drain off all the oil from the sump and refill with clean fresh oil. This should be done immediately following a run, when the oil being warm, flows more readily and will carry away any impurities which may accumulate. Do not flush out the engine with paraffin, as some will remain and contaminate the fresh oil.

Every 8,000 miles, remove the sump and clean out with paraffin, allowing it to drain thoroughly and dry out well before replacing it.

CAUTION.

Do not remove the oil gauze which surrounds the pump, as the set screws also hold the pump cover in place. Do not attempt to clean out the sump with paraffin without removing it from the engine as any paraffin remaining will cause dilution of the new oil.

It will here be of interest to explain briefly the course followed by the oil from the sump.

The working parts of the engine are lubricated by the oil contained in the sump, drawn through a filter by a gear type pump, and delivered under pressure to the crankshaft journals, crankpins, camshaft bearings and push rod guides, the spray from these bearings being ample to provide efficient lubrication of the piston little end and timing chain.

The overhead valve gear is lubricated by direct feed through a passage formed in the cylinder block and connected to the cylinder head via an external copper pipe, the oil returning to the sump by gravity through suitable passages formed in the head and cylinder block.

Suitable oil return worms are embodied at the front and rear ends of the crankshaft, which effectively prevent oil leaking along the shaft.

A by-pass oil filter is incorporated in the oil circuit and the only attention required to this is to see that the filtering element is removed and cleaned by rinsing in petrol every 2,000 miles, and that a new element is fitted every 10,000 miles.

It is essential that these simple operations be carried out at the specified periods, to ensure the proper filtration of the oil.

When cleaning or fitting new elements, the following procedure should be adopted :—

1. Disconnect Inlet and Outlet pipes from filter.
2. Loosen mounting straps and remove complete filter.
3. Ensure that both Inlet and Outlet pipes are clear by blowing through them after removing them from the engine.
4. Ensure that the calibrated orifice in the Inlet union is quite clean and clear.
5. If fitting a new filter, transfer all removable fittings from the old to the new filter, using the new sealing washers supplied in the package.
6. Install the new filter, making sure that the pipe connections are undamaged and that they are properly tightened.
7. Run engine for a few minutes to check for oil leaks, after which re-check tightness of connections (it is advisable to re-check them again after a few days running to ensure absolute freedom from oil leaks).

The oil pressure gauge situated on the instrument panel should register 40/60 lbs. per sq. in. under normal conditions. The reading will be higher when the engine is first started up from cold, owing to the greater viscosity of the oil.

VALVE CLEARANCES.

A clearance between the valve stem and rocker is necessary to ensure correct closing of the valves and efficient running of the engine.

The correct running clearance for both Inlet and Exhaust valves is .022", with the engine cold. If a tappet becomes noisy, it may be silenced by adjusting it to the correct clearance. Do not set the valve clearances too small or the engine will not maintain its good tune.

To adjust the valve clearances, remove the rocker cover and turn the engine with the starting handle for half a revolution after the valve to be adjusted has fully closed. Slacken the lock nut on the rocker and adjust the ball pin until the gauge is a close sliding fit between the valve stem and the rocker. Now tighten the lock nut and re-check the clearance, as tightening the lock nut will sometimes alter the setting. Repeat this operation on each valve and replace the rocker cover.

VALVE TIMING.

When any part affecting the valve timing is removed, take particular note of the markings on the chainwheel teeth; if these are indistinct, scribe marks on the face of the wheels before removing the chain. This will save the work of re-setting the timing when the parts are re-assembled, as they can simply be set to the marks.

if the marking operation has been neglected, the camshaft can be set as given on page 4. It is only necessary to time one cylinder, as all the cams are integral with the shaft.

IGNITION TIMING.

The ignition timing is correctly set at the works and should not normally need adjustment.

If the setting is disturbed at any time it may be re-set as described below.

The ignition advance is automatic, and should be set to fire at top dead centre, and will be automatically at full retard when the engine is at rest. We would emphasise the advantage of setting the distributor correctly, so that the automatic range may function as designed.

Turn the engine until No. 1 valve closes and continue turning until No. 1 piston reaches top dead centre. This position is indicated by a mark on the flywheel, but if the clutch housing is in position this mark will not be visible, in which case the top dead centre position for No. 1 cylinder is mid-way between the point of opening of the inlet valve and the point of closing of the exhaust valve, on No. 4 cylinder, when the engine is turned in a clockwise direction.

If No. 1 plug is removed and a bent, small diameter rod is inserted through the plug hole, it will be possible to feel when the piston is on the top dead centre position.

To obtain the correct firing point, turn the crankshaft in a clockwise direction, viewed from the front of the engine. It should here be noted that the cylinders are numbered in sequence from the rear of the engine forwards, No. 1 cylinder being that cylinder farthest away from the radiator.

If the engine is in the chassis frame the crankshaft can be turned with the starting handle, but if the engine has been removed from the chassis the turning may be done either by pulling on the fan belt or by means of a spanner applied to the starting handle nut on the front end of the crankshaft.

Slacken the clamp bolt, and turn the distributor body until the contact breaker points are just separating on the flank of the cam, when the distributor arm is opposite No. 1 segment in the cover, then re-tighten the bolt.

Maximum power is obtained by giving the greatest possible advance without causing pinking. The setting recommended above should be regarded as a starting point, as individual engines may require a greater or lesser degree of advance than this. Do not, however, alter the setting by more than one degree at a time (two degrees if measured on the flywheel). The firing orders are given on page 4.

DECARBONIZING AND VALVE GRINDING.

During the course of running, carbon forms on the walls of the combustion chambers and after many thousands of miles this may cause a metallic sounding noise in the engine, termed "pinking", which is evident when pulling hard from low speeds, in top gear. It is then necessary to remove the cylinder head, scrape clean the combustion chambers and grind in the valves.

The grinding in of the valves becomes necessary in order not only to increase the efficiency of the engine, but to prevent a badly seating valve becoming worse and getting burnt. The normal period between decarbonization is about 10,000 miles and for the sake of the valves should preferably not exceed 15,000 miles.

Most owners will prefer to have these operations carried out by a competent mechanic, but for those desiring to do this work themselves the method is outlined below.

TO REMOVE THE CYLINDER HEAD.

Drain the water from the cooling system. If it is winter time and an anti-freeze solution is being used, the owner may desire to preserve the cooling water for further use. If, however, the old water is discarded, do not forget to renew the anti-freeze solution.

When the water is drained, the radiator hose can be uncoupled from the cylinder head. Next remove the rocker cover and by undoing the two nuts at the base of the distributor tower, remove the distributor and coil together, complete with the plug leads. Do not slacken the clamp bolt on the distributor body, as this would upset the timing.

It will now be necessary to remove the inlet and exhaust manifolds by uncoupling the exhaust pipe and removing the manifold nuts, but first remove the petrol pipe connections to the carburettor, and the control connections. At this stage it may be found convenient to remove the water outlet pipe from the top of the cylinder head. Remove the rockers complete with the shaft and towers by undoing the nuts at the top of the towers. The push rods cannot be removed as they are held in position by return springs, acting at the bottom of the push rods.

The oil pipe from the oil gallery to the head, which is the feed to the rockers should now be undone, together with the bolt which is screwed into the head to assist in fixing the dynamo.

Do not at first remove the cylinder head nuts completely, but slacken them individually, commencing in the centre and working outwards and diagonally, thereby avoiding any tendency to distortion of the head. Finally remove the cylinder head.

CAUTION.

Do not insert any instrument such as a screwdriver between the cylinder head and the cylinder face, in an attempt to free the head,

as this will result in damage to the gasket and may also cause damage to the cylinder head and cylinder block faces.

If the gasket joint does not separate freely when lifting the head, a blunt knife may be very carefully inserted and the joint made free.

Should any water have found its way into the cylinder bores, wipe it away immediately.

TO REMOVE THE VALVES.

Before attempting to remove the valves, a small wooden block slightly smaller than the combustion space, but a little thicker, should be prepared.

Place the cylinder head on the bench, with the wood block in one of the combustion spaces. The valve springs can now be compressed sufficiently to allow the split collars to be dismantled. The valves can now be removed and the operation repeated on the remaining combustion spaces.

Care should be taken not to mix the valves and collars. To ensure that they are replaced in their correct order, both the valves and the cylinder head are appropriately numbered.

Before starting to clean off the carbon from the piston crowns, turn the engine by hand until two of the pistons are at top dead centre, and fill the remaining bores with clean rag to prevent any chips of carbon falling into the cylinders.

NOTE.

If the engine is turned in a direction opposite to that of normal rotation the vertical distributor driving shaft will tend to lift and may cause the helical gears to disengage. To prevent this light pressure should be applied to the top of the shaft whilst the crank is being turned.

We particularly recommend that the ring of carbon formed inside the top edge of the cylinder be left intact, otherwise its removal may adversely affect oil consumption.

Now proceed to remove all traces of carbon from the piston crowns and cylinder faces, using an old screw driver or similar blunt instrument in a chiselling manner. Do not exert too much pressure on the piston crowns, otherwise the soft aluminium heads may be deeply scratched or scored, and it will be impossible to remove the carbon which will form in these scores, during subsequent decarbonizing operations.

Having completed the cleaning of the first two pistons, give the crankshaft a half turn, transferring the rags to the two cylinders which have been dealt with, and proceed to treat the remaining pistons in the same manner.

CYLINDER HEAD.

Having completed operations on the piston and cylinder faces, attention may now be given to the cylinder head, and the sparking plugs should first be removed.

Now scrape clean the combustion spaces and valve ports, taking care not to scratch the valve seats, and when completed wipe clean with a rag damped with paraffin.

Do not attempt to polish the ports with emery cloth or other abrasive, as unless proper facilities are available it is extremely difficult to ensure that all traces of the abrasive have been removed; and should any such particles find their way into the cylinder bores, serious harm may be caused.

GRINDING IN THE VALVES.

In order to ensure that the valves are gas-tight, it is necessary for the bevelled seat of the valve, and the seat in the cylinder head, to make a perfect contact when fitted together. This is achieved by grinding the two surfaces together, but care must be taken to see that each valve is ground to its correct seat in the head, as indicated by the numbers stamped on the valves.

A small tin of special grinding paste containing both fine and coarse grades may be obtained, or alternatively, a little fine emery powder moistened with engine oil may be used. Smear a little of the paste on the bevelled face of the valve, distributing it evenly over the whole of the face, and re-fit the valve into its guide.

A light coil spring may with advantage be fitted under the head of the valve for the purpose of lifting it from its seat during the grinding operation. Use either a rubber suction valve grinding tool, or a tubular tool fixed to the valve stem by means of a grub screw, to turn the valve to and fro. After each movement allow the spring to lift the valve from its seat, and turn it to a fresh position before giving the next turn. This will help to keep the grinding even.

Continue these operations until the surfaces assume an even, matt appearance, and then wipe away all traces of paste from the valve seats and ports, as any paste finding its way into the cylinder bores or valve guides would cause serious harm.

If the valve seats are in fairly good condition, it will only be necessary to use the fine paste, but if this is insufficient to produce a clean surface, a little coarse paste must be used first, finishing off with the fine paste. If the valves have become badly pitted, they should either be renewed or have their faces skimmed in a lathe. Do not attempt to grind them in if they are in this condition, or an undue amount of metal will be removed from the seats. It should be remembered that the steel valves are much harder than the cast iron cylinder head.

Having completed the valve grinding operation, the valves may now be re-assembled. Thoroughly clean and adjust the points of the sparking plugs and remove all carbon deposit which may have formed in the exhaust and inlet manifolds.

RE-ASSEMBLING.

The engine will now be ready for re-assembly, and if the instructions given for dismantling are followed in the reverse order, no difficulty should be experienced. Particular attention should however be given to the following points.

If available use new gaskets and jointing washers when reassembling. Before replacing the cylinder head gasket, it is advisable to smear it with clean grease or a wet piece of white soap, as this will help to prevent it sticking when the head is next removed. If the cylinder head gasket has been in any way damaged, it is advisable to procure a new one, as the damaged gasket is likely to leak, with consequent loss in the performance of the engine.

When replacing the cylinder head holding down nuts, tighten them gradually, starting at the centre and working outwards, to the front and rear, and at the same time diagonally. This will produce an even pressure on the gasket and prevent undue strain in the cylinder head casting.

If a new gasket has been fitted, it will be necessary after the engine has been run for a short time, to go over the nuts again and give them a further tightening.

REPLACING THE DISTRIBUTOR.

When the cylinder head is removed, the distributor vertical driving shaft may be accidentally lifted out of engagement with the oil pump at the bottom end. Before attempting to replace the distributor, make certain that the lower end of the shaft engages with the pump by pressing on to the top end while someone turns the engine with the starting handle.

To engage the distributor spindle with the top half of the driving shaft, remove the distributor cover and turn the spindle until it engages with the shaft. There is only one position in which the parts can be engaged, and thus the timing is not disturbed.

CAUTION.

Do not use force in re-fitting the vertical bracket and distributor. When the shafts are correctly engaged, the bracket will touch the cylinder head flange, and the nuts may then be tightened.

COVENTRY CLIMAX ENGINE ONLY

ENGINE MAINTENANCE

LUBRICATION.

Daily check oil level in the sump by withdrawing the dip-stick and ensuring that the oil is above the low level mark. The dip-stick shows "high" and "low" level and oil should lie between these, preferably nearer "high" level.

After the first 1,500 miles, and thereafter every 2,500 miles, drain off all oil from the sump and refill. This should be done immediately after a run, when the oil flows more readily and will carry away any impurities which may have accumulated. Do not flush out the engine with paraffin, as some will remain to contaminate the fresh oil.

Every 5,000 miles remove the sump and clean out with paraffin, allowing it to drain thoroughly before replacing.

It will here be interesting to the owner to explain the course of the oil from the sump. Upon being drawn up the suction pipe, the mouth of which is situated about $\frac{1}{4}$ " from the bottom of the sump, oil passes through a gravity operated ball valve to a highly efficient gear type pump. From here it is fed under pressure to a gallery case in the cylinder block and in turn by branch ducts to the main bearings of the crankshaft, which, being drilled, permits oil to be conducted to the connecting rod big ends. An overhead rocker feed pipe also takes its supply from the gallery above-mentioned. Here oil is led through drilled bosses in the cylinder head to the base of the rocker bracket; this in turn is drilled both down the pedestal and through the rocker pivot arms. Lastly the rocker itself is drilled to allow oil to get to the pad in contact with the inlet valve and also the push rod cup end. Flow of oil is restricted to these latter parts by the insertion of wick in the oil holes in the rocker. Provision for the removal of surplus oil is made by channels cast in the cylinder head, these channels leading to holes in the head of the cylinder block, through which the push rods operate. Flowing down these, the oil finds its way back through the crankcase to the sump, lubricating the tappets at the same time. To enable the timing chain to be lubricated, surplus oil from the oil release has been arranged to play upon the chain and chain wheels direct. Cylinder bores are lubricated by crankcase oil vapour flung from the big ends.

The oil pressure under normal conditions of running, with engine hot, should be about 40 lbs. per square inch. This pressure is higher when the engine is cold and the viscosity of the oil greater. If difficulty is experienced in maintaining oil pressure it is possible that foreign matter has lodged under the ball valve of the oil release. This is located at the front of the engine, on the near side, and after removing the aluminium cover the ball and spring should be examined and if the ball is pitted or ridged it should be renewed.

DECARBONISING.

It is advisable for the engine to be decarbonised and the valves ground in after the car has done 2,500 miles. Thereafter this operation should not be necessary more frequently than every 5,000 miles. Where possible this operation should be entrusted to a Service Station but if this is not possible the following notes will be useful:—

TO REMOVE CYLINDER HEAD.

Drain off water from radiator; take off dynamo belt and disconnect top water pipe; remove ignition wires from sparking plugs, carefully noting the position of each plug cable. Remove the two overhead inlet valve rocker covers and disconnect the brass unions which convey the oil pressure feed via copper pipes to the overhead valve rocker oil system. Disconnect the pipes from carburettor and induction pipe and after releasing the ball joint and "Rich Mixture" wire on the carburettor levers, detach carburettor and induction pipe (in one unit) from cylinder head and exhaust manifold. Following this, unscrew the large hexagon nuts which hold down the overhead rocker mountings, when the rocker mountings, each with its pair of rockers, may be lifted. Withdraw the push rods upwards and remove the cylinder head holding down nuts. The cylinder head may now be lifted from the cylinder block, care, of course, being taken of the combustion chamber gasket, although it is generally advisable to use a new gasket. If the head should be tight it will assist in freeing it if it is tapped under the lugs which will be found at the side.

VALVE GRINDING.

The valve springs should be compressed to enable the cotters to be removed and the valves ground in with a very fine emery powder moistened with oil. It will be found convenient, when grinding in valves, to place a light spring under the valve head to lift the valve off its seat; it is necessary that the valve should be turned round from time to time during the grinding process to avoid the formation of ridges on the seating. When this operation is completed, the valves, ports and combustion head should be freed from all traces of carbon and emery powder, the valves and springs replaced and the tappet clearances adjusted and checked in accordance with the details that follow.

When replacing the cylinder head, it is advisable to see that the gasket is perfectly flat and in good condition and to apply a small quantity of good quality jointing compound to each side of the gasket before replacing. It is important that the cylinder head nuts should be tightened evenly to avoid excessive pressure in one spot.

They should be tightened down, starting at the centre of the head, working outwards to front and rear, and at the same time diagonally.

It is essential to go over the nuts again with a spanner after the engine has been warmed up.

Note.—The inlet valve tappet clearances cannot be checked until the push rods, rockers and rocker mountings have been replaced. Also the head holding down nuts should be finally tightened when the rocker mountings and induction pipe have been bolted home. Do not replace rocker covers until the engine has been run for at least ten minutes and the holding down nuts re-tightened and tappets finally adjusted.

The firing order of the engine is 1, 3, 4, 2.

TAPPETS.

Tappets should be adjusted to the following clearances :—

Inlet—.006".

Exhaust—.008".

The tappets should be set when the piston in the corresponding cylinder is at the top of the compression stroke.

IGNITION TIMING.

Ignition should be set with the piston at top dead centre, contact breaker points just separating, micrometer adjustment in the mid-way position.

CONTACT BREAKER.

The gap between the contact breaker points when fully separated should be .012"—.015" and may be checked with the gauge provided on the spanner supplied.

TIMING CHAIN.

To adjust the timing chain when necessary, the three bolts holding the distributor drive housing should be slackened off a little, when the aluminium flange, together with the drive housing, can be pivoted about the bottom securing bolt, thus by swinging the assembly outwards the chain is automatically tightened. The chain, however, must not be run dead tight. When correct adjustment has been obtained the housing securing bolts should be re-tightened, care being taken not to alter the adjustment while so doing.

DYNAMO BELT.

Slack off the securing bolts and swing outwards and upwards (this movement being governed by the pivoting bosses on the water outlet pipe and the adjustment link plate). When correct belt tension has been obtained, re-tighten securing bolts.

SPARKING PLUGS

A little regular attention to the sparking plugs will ensure that the maximum efficiency is obtained from the engine.

Fig. 3 illustrates the Champion Plug, type NA-8, which was fitted as standard equipment to the Morgan Model 4/4 (Replacement No. now Y5).



Fig. 3

The Sparking Plug is of such great importance in satisfactory engine performance, that every care should be taken to fit the correct type when replacements are necessary. The make and type of sparking plug fitted by us as official factory equipment is best suited to the requirements of the motor.

Correct gap setting of sparking plugs is absolutely essential to good engine performance and the recommended gap setting is .025".

It is a real economy to have sparking plugs cleaned and checked at regular intervals and it is suggested that this service be performed at your usual garage on a special service machine. Plugs which are allowed to remain oily and dirty and with corroded electrode wires, will seriously impair the efficient running of the motor and also prevent easy starting.

When replacing the plugs, make sure that the washers are not defective in any way, and if they are flat and worn, fit new ones to ensure obtaining a gas-tight joint. When fitting, take care not to

CHASSIS LUBRICATION DIAGRAM

Sliding Axles.
Apply grease gun every 500 miles.

Front Hub.
Remove hub cap and re-pack with grease every 3000 miles.

Brake Cable.
Apply grease gun every 3000 miles.

Pedal Brackets.
Apply grease gun every 3000 miles.

Clutch Thrust.
Apply grease gun every 3000 miles.

Shaft Slip Spline.
Apply grease gun every 3000 miles.

Brake Cable.
Apply grease gun every 3000 miles.

Rear Axle.
Remove filler every 3000 miles and re-fill as necessary.

Rear Spring.
Every 5000 miles have lubricant applied between leaves by Service Garage.

Sliding Axles.
Apply grease gun every 500 miles.

Front Hub.
Remove hub cap and re-pack with grease every 3000 miles.

Brake Cable.
Apply grease gun every 3000 miles.

Steering Box.
Remove plug every 5000 miles and re-fill with oil.

Contact Breaker Pivot.
Apply spot of oil every 5000 miles.

Sump.
Check oil level every 500 miles and bring up to high-level mark on dipstick.

Pedal Brackets.
Apply grease gun every 3000 miles.

Clutch Thrust.
Apply grease gun every 3000 miles.

Gearbox.
Remove filler cap every 1000 miles and top up as necessary.

Shaft Slip Spline.
Apply grease gun every 3000 miles.

Rear Hub.
Apply grease gun every 3000 miles.

Brake Linkage.
Apply spot of oil every 3000 miles.

Rear Spring.
Every 5000 miles have lubricant applied between leaves by Service Garage.

Rear Spring Slide.
Apply grease gun every 500 miles.

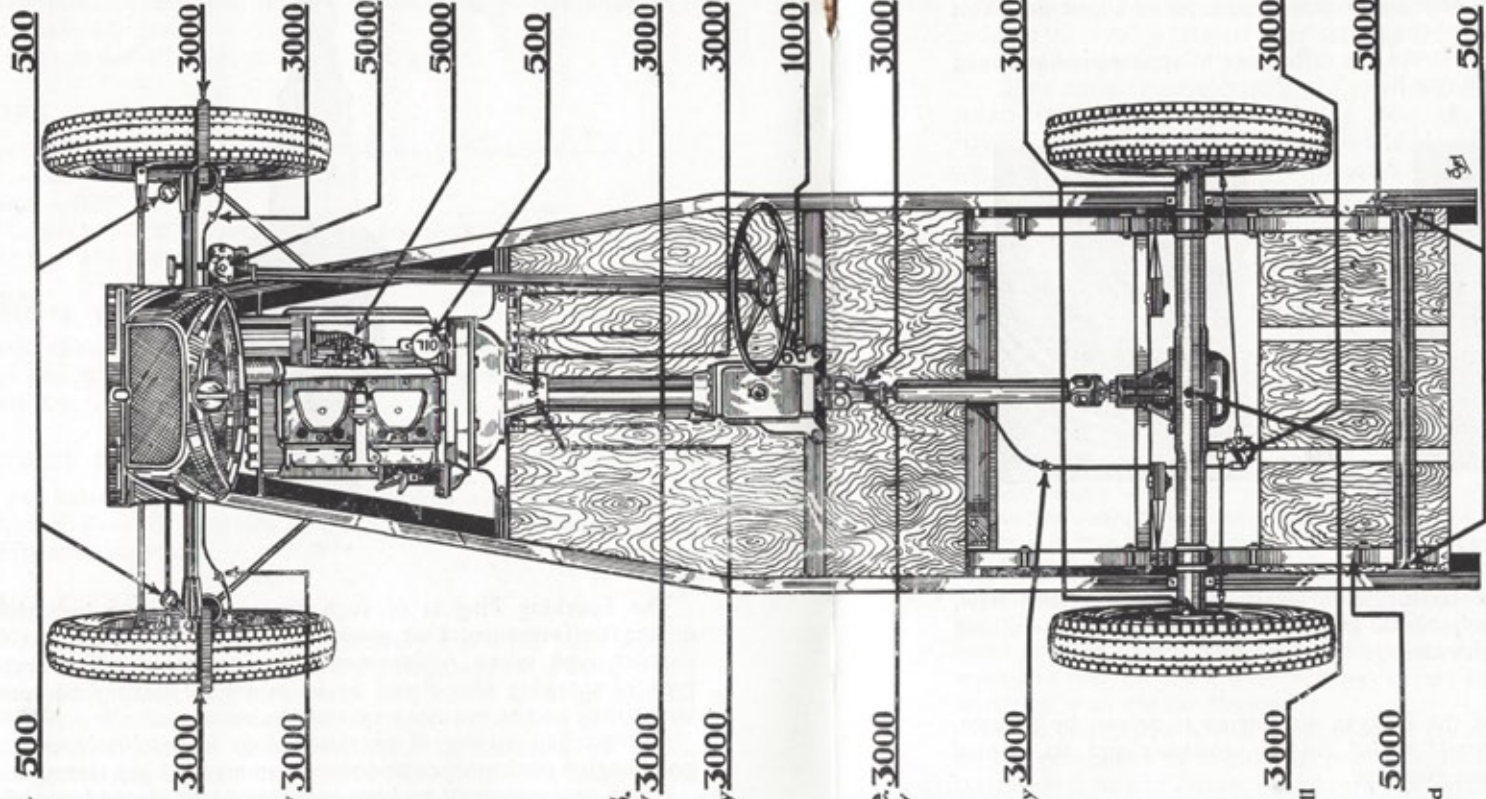

FIGURES GIVEN ABOVE INDICATE MILEAGES AT WHICH LUBRICATION SHOULD BE CARRIED OUT

ALSO REQUIRING ATTENTION

Go over car periodically and apply oil to front brake linkage, various controls, door hinges, locks, etc. At the same time go round with spanner and tighten any nuts that may have worked loose. Find cause of rattles or squeaks and rectify. Check wheel track - wheels should 'toe-in' - not more than $\frac{1}{8}$ Top up batteries and radiator weekly, also check tyre pressures. Correct pressure 18-20 lbs per square inch.

knock the top insulation of the plugs, for although it has a strength which is greater than usual, a heavy knock may fracture the insulation and mis-firing will occur.

It should be remembered that cheap oil and petrol, improper carburettor adjustment and excessive use of the choke will have the effect of causing the insulation to become foul and dirty, and also if the high tension leads are old and the rubber has become hard and cracked, electrical leakage may occur, with the result that the plugs will mis-fire. If the distributor points are out of adjustment this may also cause fouling of the plugs.

(Figs. 4a and 4b illustrate the difference in appearance between a clean plug and a foul one.)



Fig. 4a



Fig. 4b

To obtain maximum efficiency from the engine, and also to maintain the good petrol consumption which the car has when new, change the plugs every 10,000 miles, as old plugs are wasteful and give poor and sluggish running.

TIMING CHAIN.

The timing gear of the Morgan 4/4 engine is driven by a chain, fitted with an automatic spring loaded tensioner and no manual adjustment is therefore required.

CENTRALIZING THE TIMING COVER.

If the timing cover is removed at any time, it should be replaced in the following manner, in order to ensure correct oil retention and quiet running.

First replace the timing cover with the securing screws just holding, then place a drop of oil on the inside of the crankshaft pulley and fit the pulley on to the shaft, but with the driving key removed. The pulley will not revolve freely if it rubs on the hole in the timing

cover, in which case tap the sides of the cover until it is possible to spin the pulley, and then tighten the securing screws.

It is advisable to re-check the pulley for freedom after tightening the securing screws, to make sure that the cover has not moved in the process of tightening. Finally, fit the pulley key and tighten up the crankshaft nut.

CARBURETTOR.

The correct size of choke and jets are fitted to the carburettor, and it is inadvisable to alter them as they are the result of exhaustive bench and road tests.

Slow running adjustments are provided and these are the only points that may require attention after the engine has become run-in. Two adjusting screws are provided on the carburettor: one for limiting the closing of the throttle, and thus the idling speed, and the other to regulate the strength of the idling mixture. There is also a screw which sets the full open position. Do not interfere with this.

We recommend that the carburettor be set to run at a fairly fast tick over, or idling speed, because an engine which is regulated to a minimum speed when hot, is apt to stall when cold. The correct jet sizes are set out on page 4 of this handbook.

The "Self Starting" Solex carburettor is so called by reason of the special starting device, which provides a properly balanced mixture of air and petrol for starting purposes independently of the main carburettor.

In consequence, when preparing to start the engine, the throttle of the main unit must be kept closed (to the normal idling limit) such as is the case when the pedal is not depressed, so that full suction is imposed on the starting device.

Start as instructed in Chapter I, and drive away at a reasonable speed directly the engine is started. The secondary function of the Solex starting device is to enable this to be done, and the resultant wear and tear on the engine will be far less than by allowing it to warm up with the car stationary.

When the engine is well warmed after say running half a mile or so, the dashboard knob must be pushed right home. This puts the starter unit out of action, and it will not again be required, unless the car is left standing so long that the engine cools down beyond the point where it will not start on the pilot jet mixture from the main carburettor.

It is important to note that the dashboard knob is either pulled out fully, or pushed completely home. It must never be set in a half-way position, for this will completely upset the starting mixture, and cause an excessive quantity of petrol to enter the cylinders.

The adjustment of the starting device is permanent, and as a unit

therefore it can be disregarded except that both the air jet and the petrol jet should receive ordinary attention occasionally to make sure that there is no obstruction by foreign matter.

The combination of petrol and air jets should never require alteration, provided the engine is kept in good mechanical condition.

Failure to secure easy starting under all weather conditions, and clean get-away from cold can only be due to failure of the petrol supply, occasioned by dirt or water or some electrical or mechanical failure of the engine.

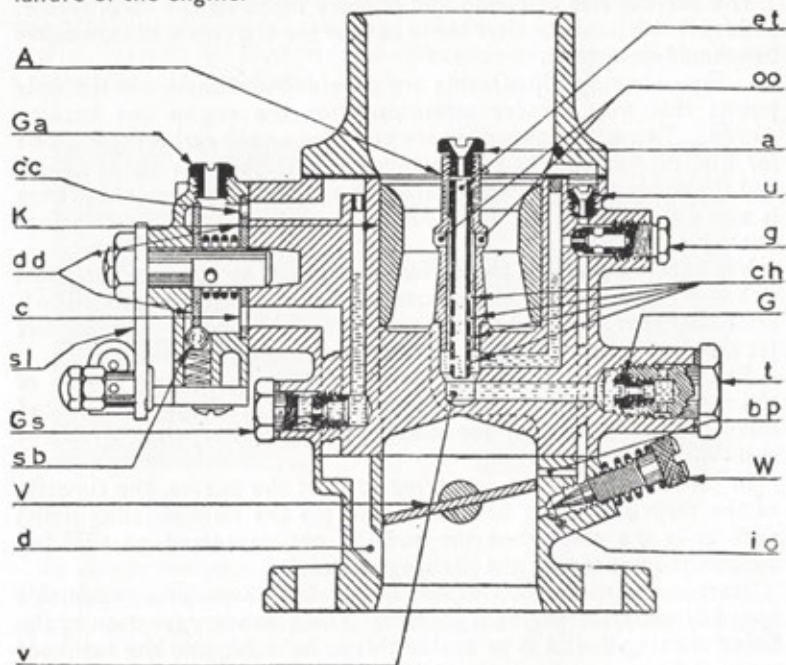

Fig. 5

It will be seen that the volume of petrol passing from the pilot jet (t) is governed by the volume control screw, fitted beneath the throttle tube.

The volume control screw (w) obviously governs the supply of mixture to the engine for slow running purposes and it follows that slackening off, *i.e.*, in an anti-clockwise direction, will enrich this mixture and *vice versa*.

If, therefore, when the engine is warm "hunting" takes place, or black smoke is seen to issue from the exhaust, the mixture is too rich, and the volume control screw must be turned in a clockwise direction until stable idling is secured.

If, on the other hand, the engine stalls, or erratic running (which must be ascertained is not due to defective plugs, etc.) persists, the idling mixture is too weak, and anti-clockwise adjustment of the screw is indicated.

Actual engine speed when idling is determined by adjustment of the spring loaded screw fitted to the abutment plate carrying the throttle lever. Turning in a clockwise direction will increase the minimum throttle opening, and so cause the engine to run faster.

ADJUSTMENT OF JETS.

Pilot jet. An engine which has had a fair amount of wear and tear, but is not yet in such a condition that reboring is necessary, may not idle satisfactorily with the original size of pilot jet, no matter how carefully the volume control screw is adjusted. In such circumstances, a larger pilot jet will frequently restore stable idling until such time as the engine is completely overhauled.

Main jet. When an engine has been carefully and well run-in, it will occasionally take a size smaller main jet in the carburettor, without detracting from the general performance.

If, therefore, it is found that ample power is being obtained and there is no symptom of weak mixture, such as spitting back excessively in the carburettor during cold weather, when opening the throttle, it may be worth while to try a smaller main jet, for it is possible that in the summer, even if not all the year round, good results will be obtained from it, and a few more miles to the gallon into the bargain.

Inspect occasionally, the filler gauze carried inside the petrol pipe union at the top of the carburettor; this will need cleaning occasionally, and if symptoms of petrol starvation occur on the road, probably attention to this item is all that is necessary.

These are the only adjustments to the carburettor that need consideration.

Flooding. If it is observed at any time that the carburettor leaks (but not at any of the joints), examine first the float. A shake will tell if petrol is inside. This is a delicate component and may become sprung if exposed to violent shocks. Dropping it on the ground, for instance, when cleaning the carburettor, may cause it to leak.

A new one is the proper remedy. If the leak is soldered, the balance will be upset and cause trouble in other ways, besides probably increasing the leak, due to the float tilting and sticking in the float chamber.

If the float is perfect, dirt in the needle valve may be the trouble.

Remove it bodily from the float chamber cover, and swill in a container of petrol or paraffin. If on replacement the leak persists, then the seating has been scored. If not scored too deeply a new

seat can be made by tapping the end of the needle with, say, a light double-ended spanner, rotating the needle between each two or three taps. If this is unavailing, a new valve needle will be required.

It will be seen from the foregoing, that only the tools provided in the kit are necessary for dismantling the carburettor, viz. : a screw-driver and adjustable spanner.

A FINAL NOTE.

When the engine is due for overhaul, do not overlook having the carburettor overhauled at the same time.

Moving parts are subject to wear, and to obtain maximum performance it is equally important that the carburettor is in the same satisfactory condition as the engine.

PETROL PUMP.

The petrol pump is mounted on the side of the crankcase, and is operated by an eccentric cam. A sectional view is shown in Fig. 6.

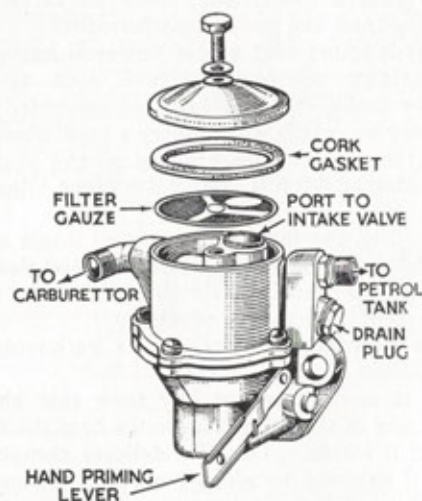

Fig. 6

Petrol flows through a strainer before passing through the non-return inlet valve. The pump chamber contains a non-return outlet valve and at the lower end a diaphragm operated by a pull rod from the rocker arm which is in contact with the lever. The rocker arm constantly oscillates and if the pump chamber is full of petrol, causing the diaphragm to be depressed, the rocker arm works freely and does not operate the diaphragm. The spring behind the

diaphragm provides a constant pressure of fuel to the carburettor float chamber, and thus the stroke of the diaphragm is automatically governed to meet the requirements of the carburettor. The rocker arm itself is spring loaded for the purpose of keeping the lever in contact with the cam and preventing noise. There is a drain plug fitted to the sediment chamber.

There are filters incorporated in the petrol pump and carburettor unions.

A hand primer is fitted to the pump so that it is unnecessary to turn the engine either by hand or by the starter if the tank has run dry and the pump becomes empty. A few strokes of the hand primer will soon fill the float chamber. It may be necessary to carry out this operation if the car has stood for several days without being used.

If the pump fails to supply petrol to the carburettor, attend to the following points.

Remove the filter cover and thoroughly clean away all deposits in the filter chamber. Here again dry deposits are comparatively harmless, but any gumminess, apart from being cleaned out of the filter chamber, must also as far as possible be washed out of the pump. The filter gauze should be cleaned either by rinsing it in petrol or blowing it on an airline, and then the gasket under the filter cover should be examined and if unduly compressed or cracked a new one fitted. Finally, the filter cover should be replaced and tightened, care being taken to ensure that apart from the gasket under the outer edge, the small washer employed under the head of the centre screw is also present.

Next, re-connect the rear pipe to the pump but disconnect the delivery pipe up at the carburettor end, so that a delivery test can be made. To do this some fresh petrol should be put in the tank, and with the pipe up at the carburettor end disconnected, the pump should be operated either by the priming lever or by turning over the engine, and if everything is in sound condition there should be a positive delivery of petrol every working stroke of the pump. If as referred to earlier on there were any gummed deposits in the pump filter chamber, this testing process of the pump should be prolonged so as to thoroughly wash out its interior, as even a slight trace of gum can result in sticking, not only of fuel pump valves, but also the carburettor needle valve.

CLUTCH, GEARBOX, TRANSMISSION SHAFT and REAR AXLE

CLUTCH.

This is of the single dry plate type, and needing no adjustment. It is totally enclosed.

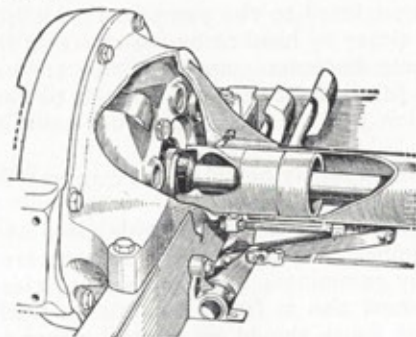

(By courtesy of "The Motor")
Fig. 7

An aluminium sleeve, sliding within the tube enclosing the shaft to the gearbox, operates the Borg and Beck clutch through a graphite thrust bearing. To allow easy operation lubricate as directed in Chapter II. At all times there should be a small amount of play in the clutch pedal. This will increase with use and when it is desired to take up excess play, adjustment is made on the rod underneath the shaft tube.

GEARBOX.

This requires no adjustment or attention beyond replenishment of the oil at the periods given in the lubrication chart. Should for any reason the cover of the box be removed, it should be done with great care, otherwise one or more of the three springs and pawls which load the gear selector rods is likely to be dropped into the box. After removing the screws, it is advisable to slide the cover backwards before lifting.

TRANSMISSION SHAFT.

The Hardy Spicer Needle Bearing type universal joints require no other attention than that mentioned in Chapter II. Usually, long and severe service is required before any appreciable wear is noticed. The trunnions and needle bearings are the only parts

subject to wear, and when replacement is finally necessary they may be removed and replaced by hand without the need for special tools. The needle bearings are locked in position with lock rings held on recessed grooves in the yokes, requiring only a pair of pliers for removal. If for any reason there is necessity to remove the bearing assembly, be sure to hold the trunnion in an upright position, so that the assembly to be removed is at the bottom. This is necessary in order to prevent the needles from falling out. In the event of their doing so, the assembly should be washed in petrol and then by smearing them with light oil or vaseline, to hold the needles in position, the bearings can readily be re-assembled. Do not use grease when re-assembling as this is liable to clog the oil passages, use a light oil. The joints have four independent oil reservoirs which carry the oil to the needle bearing assemblies. Each Universal coupling is fitted with a grease nipple, and a third nipple is provided for the slip spline shaft (Fig. 8) and is indicated on the lubrication chart. Lubricant should be applied every three or four thousand miles.

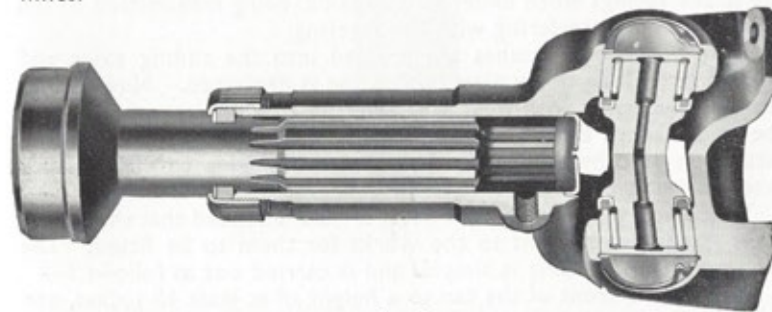

Fig. 8

REAR AXLE AND DIFFERENTIAL.

The rear axle fitted to the Morgan model 4/4, is of the four star wheel type, and is of extremely sturdy construction, and should require no attention other than correct lubrication as indicated on the chart. To replenish the oil in the rear axle, remove the overflow plug which is situated in the spiral bevel housing, under the passenger side axle shaft casing.

Pour oil in through the filler at the top, until it commences to run out through the overflow, after which replace the plug.

When draining the oil from the rear axle casing, in order to replace it with fresh clean oil, it is advisable to carry out this operation immediately following a run, as the oil, being then warm, will flow more readily.

Grease the rear hub bearings periodically as indicated on the lubrication chart.

STEERING, FRONT AND REAR SUSPENSION AND SHOCK ABSORBERS

The front wheels are suspended independently, and slide vertically on the main axle pins which hold the complete assemblies in position.

The sliding axles, wheel spindles, and brake plates form complete units and require no other attention than that of lubrication as directed.

All later models of the Morgan 4/4 car are fitted with simple steering dampers, consisting of a flat spring steel arm, secured at one end to the chassis, and fitted at the other end with a phosphor bronze ring which is assembled between the main coil spring and the top face of the stub axle body.

The purpose of this damper is to prevent any twisting motion set up in the springs when under compression, being transmitted to the stub axles and interfering with the steering.

Phosphor bronze bushes are pressed into the sliding axles and should last a long time unless lubrication is neglected. New bushes become necessary with wear, but a period at which renewals should be made cannot be laid down, as this is primarily dependent on the attention or otherwise which the owner may give to maintenance and lubrication.

When new bushes are required, it is recommended that the sliding axle assemblies be sent to the works for them to be fitted. The method of dismantling is simple, and is carried out as follows:—

Jack up the front of the car to a height of at least 15 inches, and remove the road wheels. It is advisable to put suitable blocks under the front of the car, in order that it will remain firm while this work is being carried out. Remove the pins from the track rod ends, uncouple the brake cables from the balance lever on the bottom axle tube and remove the nuts over the top axle tube and lugs. Next, remove the nut from the bottom axle end lug plate. Precaution should be taken when finally removing these two bolts, to see that the rebound spring does not fly out.

When re-assembling, see that all nuts are properly tightened. Check the front wheels for correct alignment (see Chapter VII).

The Steering Column calls for no attention beyond occasionally removing the plug from the oil filter and refilling with oil. The drop arm connecting the column to the drag link fits on a spline and if at any time it is removed care should be taken to see that it is replaced on the correct serration. A simple adjustment which requires no explanation is provided at either end of the drag link when found to be required.



Fig. 9

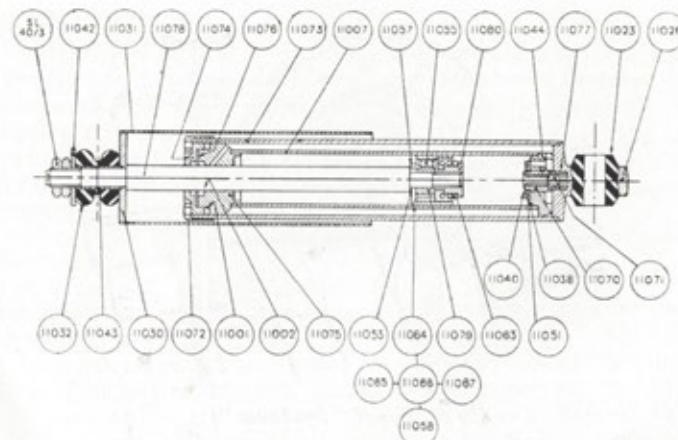

Fig. 10

Newton hydraulic dampers are fitted to the front sliding axles, and these are correctly adjusted when fitted at the works, and do not require any further attention.

REAR SUSPENSION.

Fig. 11 and Fig. 12 show the position of the rear springs, inside the frame, and also the method of mounting. The front ends are carried in "Silentbloc" bushes, and require no attention.

The rear ends of the springs slide in specially designed trunnions which are shown in the diagram. The position of the grease nipples is clearly indicated. The nuts on the "U" clips holding the springs to the rear axle should be examined occasionally, and tightened if necessary.

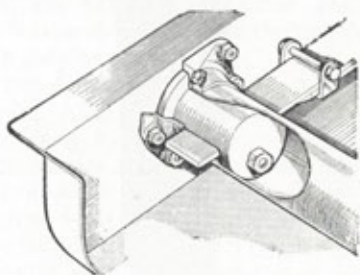

(By courtesy of "The Motor")

Fig. 11

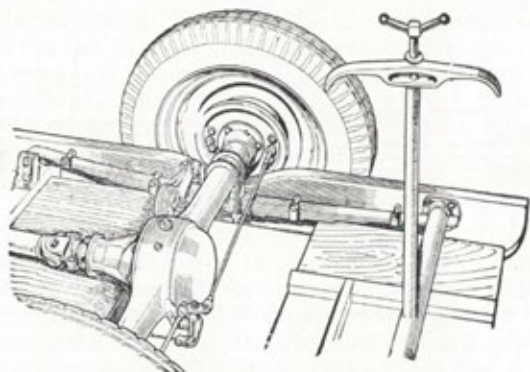

(By courtesy of "The Motor")

Fig. 12

The rear springs are fitted with Andre Multiplex Shock Absorbers which are set to a certain initial tension before the car leaves the factory. No change in this adjustment should be made until the car has been driven about 500 miles on both good and bad roads, and at no time should the shock absorbers be adjusted up dead tight.

Carefully note the riding qualities of the car. If the spring action seems too free, increase the frictional resistance of each Shock Absorber by turning the centre adjusting nut to the right or clockwise, by not more than one graduation at a time.

If the spring action seems too retarded and feels stiff, reduce the frictional resistance again by turning the adjusting nut to the left or anti-clockwise. Careful adjustment in this manner will produce an ideal condition. The springs will still have the required amount of flexibility for easy riding, but spring vibration will be reduced to a minimum and violent rebound effectively eliminated.

Re-adjustment may only become necessary after several thousand miles of car travel, and should only be made when the spring movement seems too free, and then the indicator should be moved not more than one-half of a graduation at a time.

It should be noted that the full benefit of the Shock Absorbers will not be felt when the car is travelling at low speeds, as under these conditions the spring movement is very limited, but as the speed increases their effect becomes more pronounced, especially over bad roads when the spring action is most severe.

Testing should therefore be carried out at comparatively high average touring speeds, and adjustments made to suit these conditions.

IMPORTANT.

The frictional resistance required to effectively control the action of the springs is comparatively small and care should be taken not to increase the pressure more than is absolutely necessary, when adjusting to obtain the desired results. The initial setting of the Shock Absorbers is approximately correct under normal conditions, but for road and track racing a considerable increase in pressure may be required.

BRAKES

The Girling brake fitted to the Morgan is a simple mechanical brake operated by rods and cables. The shoes themselves are operated by a self-contained expander, which is practically frictionless, and which is also completely enclosed and protected from mud and water. Adjustment is by a self-contained enclosed adjuster unit, operating on the fulcrum-end of the brake shoe. The linkage is an assembly of straight rods, which are in tension, and short cables, all of which are equally loaded. Furthermore, the load on these rods and cables is very low, owing to the low leverage employed.

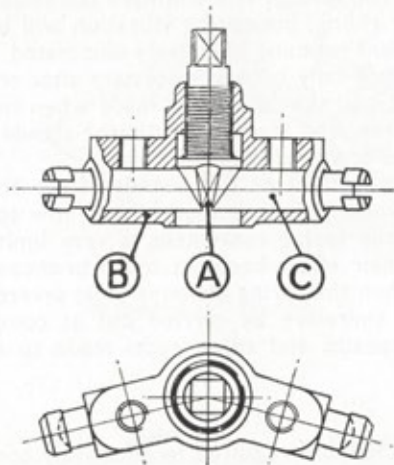

Fig. 13

BRAKE SHOE EXPANDER.

The Diagrams show the brake expander, and the brake shoe adjuster, Fig. 13. The shoes are expanded by the action of the hard steel cones which are actuated at the front by cable and at the rear by transverse rods; the cones operate hardened steel plungers which bear on the brake shoe ends, hardened steel rollers are interposed between cones and plungers to reduce friction to a minimum. It should be noted that these rollers are freely mounted and roll in grooves in the plungers; they are not pivoted or restrained in any way. The cones, rollers and shoe plungers are enclosed in a die-cast housing which retains an adequate supply of lubricant, and protects them from mud, etc. This casting is slideably attached to the brake backplate by studs and nuts, with spring washers. It

should be noted that this casing is not required to withstand any of the stresses set up by braking, as it virtually floats between the shoes and is only a covering element. By reason of this fact, it is obvious that the brake shoes are self-centring under the action of the pull-off springs.

BRAKE SHOE ADJUSTER.

Adjustment for brake lining wear is obtained by rotating (in a clockwise direction) the hardened steel cone (a) (this cone has four flats of a predetermined depth machined on its face). The cone engages the two plungers (c), also with inclined flat faces, on which the shoes are fulcrumed. The cone spindle is screwed with a fine thread and located in a steel housing (b) firmly spigoted and bolted to the back plate; this housing also carries the two plungers (c). Rotation of the cone causes it to move outwards, forcing apart the plungers and expanding the ends of the shoes. The flats on the cone face perform two useful functions:—(a) the action of the Brake Shoe springs on the plungers; (c) serves to lock the cone in position when adjustment is carried out; and (b) the depth of the flats is such that they allow exactly the correct amount of shoe clearance in the drum when adjusted. There is only one adjuster on each wheel and the alteration of this is the only adjustment that should be necessary. It is extremely rapid in operation.

BALANCE.

The front wheel brakes are compensated, also the rear. A simple swinging link balances the applied effort to the front and a rocking pivot does the same for the rear wheels.

The rod connecting the pedal to the front swinging link balances the applied effort between front and rear. Adjustment is correct when the car leaves the factory and should not be interfered with when carrying out the adjustments previously described.

RE-LINING.

1. Jack up the car in the manner previously described, and remove the road wheels.

Remove drums. The rear wheel drum is secured by two countersunk screws; remove them and the drums can be tapped off, disclosing the brake shoes, etc. In the case of the front wheel drum, it is necessary to remove the complete hub, and this can only be done by the use of a suitable drawer.

2. To dismantle the brake, all that is required is a large screwdriver. With this it will be found quite easy to prise one shoe out of the groove in the plunger at expander end. Both shoes and springs

can now be removed, leaving expander and adjuster units in position on the back plates. Be careful not to over stretch the springs when removing the shoes.

3. Clean down the back plate, check expander and adjuster units for free working. Slack back adjuster (anti-clockwise) to full off position. Adjuster cone spindle should screw quite easily into the housing. Inspect the shoe pull off springs and replace if damaged.

4. Detach springs from old and re-fit to new shoes. Be sure that the springs are between shoe webs and back plate, otherwise the shoes will not lie flat on the plate. Keep all grease off the brake linings. Place shoes, with springs attached, against the back plate. Fit shoe ends to adjuster grooves. Shoes have half round slots at one end ; fit these slots to the adjuster plungers ; then insert the other end of the shoe in expander plunger. Insert screwdriver under web of the remaining shoe and ease into plunger groove.

5. Re-fit drums. Be sure they are clean and free from grease, etc.

6. To ensure correct clearance between the shoes and drums, slack off set pins that hold adjuster to back plate one complete turn and lock up brake shoes in the drum by turning the adjuster in a clockwise direction. Bolt up adjuster set pins tightly and slack off adjuster one full notch. Give the brake pedal a firm application to ensure that the shoes have centralised. Drums should now be quite free.

7. Re-fit road wheels. The operation of relining is now complete and nothing further is required.

IMPORTANT.

DO NOT tighten up the brass expander nuts on outside of back plate.

DO NOT handle linings with greasy hands.

DO NOT over stretch pull off springs when removing shoes.

DO NOT remove expander and adjuster housings from back plate.

DO NOT forget to tighten up firmly, adjuster housing set pins.

DO NOT fit any other than "Girling" replacement shoes which are correctly rivetted, and ground to correct periphery, which ensures a fast and easy bed-in to drum.

JACKING SYSTEM, WHEELS AND TYRES

The jack is used in the following manner :—

First remove the seat from whichever side of the car it is intended to raise ; lift mat and open metal cover over hole in floorboard ; insert jack through hole, mushroom head first ; push pin through hole in chassis cross member and operate by screwing in a clockwise direction with the same tool as that used for wheel nuts. It will be noted that the lug can be adjusted to any desired position according to the position of the car. It is essential that the jack be placed in relation to the angle at which the car is standing, *i.e.*, if on a perfectly flat surface it should be just off upright ; if on a cambered surface it should be so placed that when the car is lifted there is no possibility of sliding either way.

WHEELS.

In the normal course of wear and tear, or due to minor impacts, the wheels may develop irregularities, or cease to point directly in the direction of motion. A check should be made periodically to ensure that the wheels are in correct alignment or "track". Every garage possesses an alignment gauge and can carry out a test in a few moments. Errors in alignment can be corrected by adjustment of the track rod, the ends of which are threaded for this purpose. The "Toe-in" for the front wheels should not exceed $\frac{1}{8}$ ". "Toe-out", even in the smallest degree, is to be avoided. Rear wheels should be parallel.

The recommended tyre inflation pressures, front and rear, are 18-20 lbs. per square inch, for 17 X 4.50 size and 16 X 5.00 size. Test these pressures weekly, and make sure that all the tyres are the same.

GENERAL

HOOD.

When erecting the hood, always fix the eyelets in the back curtain over the turn-buttons first and then fix the snaps across the top of the windscreen. If secured at the front first some strain will be necessary to pull the eyelets over the turn-buttons, which in time will pull away from the fabric. Likewise, when dismantling the hood release the cover from the front first; do not strain the eyelets over the turn-buttons. It is not intended that the tonneau cover over the rear compartment should remain in position when the hood is up as the turn-buttons do not allow for the double thickness, and unnecessary strain is placed on the hood fabric and turn-buttons alike.

When standing and rain is imminent it may be noted that the loose hood top makes a useful tonneau cover if fitted in the usual way without erecting the hood frame.

SIDE CURTAINS.

It should be remembered that celluloid is easily scratched and soiled, spoiling vision at the sides. When not in use, therefore, do not throw the side curtains carelessly into the rear compartment so that they are free to move about and rub.

REPAIRS.

Our repair depot is especially equipped to take care of customers' requirements, and can at all times undertake anything from adjustments to major repairs and complete overhauls, at reasonable charges consistent with expert workmanship. Machines or parts sent for repairs should be consigned carriage paid and should be clearly labelled with the sender's name and address. Instructions should be sent separately, stating whether an estimate is required before putting the work in hand. When inconvenient to send repairs to the works an accredited "Morgan" dealer should be consulted.

MORGAN 4/4 CLUB

As you are now the possessor of a Morgan Car, you may care to share your enthusiasm with other current or previous owners of Morgan cars.

To this end, the Club which was founded by a group of enthusiastic owners exists to promote meetings of a social and competitive nature for its Members. It is recognised by the R.A.C. for the promotion of such events, and is associated with the Midland Association of Car Clubs.

The President and Chairman is, Mr. Peter Morgan, and the Club enjoys a favourable degree of Factory encouragement and support.

Your 30/- Annual Membership in Great Britain, or 15/- for Overseas Membership, entitles you to participate in all Club events, which include the entire range of motoring competition—i.e. Rallies, Driving Tests, Sprints, etc., and every kind of Social activity. We also receive many invitations to other Club events, and you will be kept notified of these activities through the Monthly Miscellany, the Editor of which will be grateful for any contributions in the form of articles, experiences or criticisms.

You are also entitled to purchase and display car badges, ties, flannel scarves or silk squares, also lapel badges, all bearing the Club emblem and colours.

As a historical fact, the Club was founded in 1951, and has acquitted itself well by winning team awards in National Rallies and Races.

So may we invite your application for Membership, to enable you to share our activities ?

A. P. SMITH, Esq., *Club Secretary*,
1, Avon Street, EVESHAM, Worcs.

WARRANTY

The goods manufactured by the Morgan Motor Co. Ltd. are supplied with the following express Warranty which excludes all warranties, conditions and liabilities whatsoever implied by Common Law, Statute or otherwise, that is to say :—

In the event of any defect being disclosed in any part or parts of the goods and if the part or parts of the goods alleged to be defective are returned to the Company's Works carriage paid within six months from the date when the goods are delivered new to the retail customer, the Company undertakes to examine same and should any fault due to defective materials or workmanship be found on examination by the Company, it will repair the defective part or supply free of charge a new part in place thereof.

This warranty is limited to the delivery to the purchaser free at the Company's Works of part or parts whether new or repaired in exchange for those acknowledged by the Company to be defective.

The Company gives no warranty of the goods except as herein stated, but desires and expects that customers shall make a thorough examination before purchasing.

Persons dealing in the Company's goods are in no way the legal Agents of the Company and have no right or authority to assume any obligations on its behalf expressed or implied or to bind it in any way.

For the purpose of this Warranty the term "Goods" means and includes new cars or vans or chassis or parts thereof including replacements parts manufactured by the Company.

It does not include Tyres, Speedometers or Electrical Equipment or other proprietary articles or goods not of the Company's own manufacture although supplied by the Company. Proprietary Articles are covered by the warranty (if any) given by separate manufacturers. On second hand goods no Warranty is given by the Company or is to be implied.

The Company's responsibility is limited to the terms of this warranty and it shall not be answerable for personal injury, or consequential or resulting liability damage or loss arising from any defects.

The Warranty is dependent upon the strict observance by the purchaser of the following provisions :—

(a) The purchaser shall send to the Company's Works such part or parts as are alleged to be defective promptly on discovery of the claimed defect. Transportation is to be prepaid and the said part or parts to be properly packed for transport and clearly marked for identification with the name and full address of the purchaser and with the car and chassis numbers of the vehicle from which the parts were taken.

(b) The purchaser shall post to the Company on or before despatch of such parts as are alleged to be defective a full and complete description of the claim and the reasons therefore.

(c) The decision of the Company on all claims shall be final and the purchaser agrees to accept its decision on all matters relating to defects and the exchange or replacement of parts.