

LA SALLE

OPERATOR'S
MANUAL



LA SALLE

Operator's Manual



CADILLAC MOTOR CAR COMPANY
DETROIT

COPYRIGHT 1927 BY
CADILLAC MOTOR CAR COMPANY

EDITION No. 303-3

*In ordering a duplicate of this Manual specify the
above number or the engine number of the car*

To the New Car Owner—

Parts I and II of this Manual contain information that you must know in order to operate and care for your car properly. This section should be read carefully as soon as possible after taking delivery of the car.

Part III contains information that you will not need until occasion arises. We suggest that you do not read this part at once, but keep the book in the cowl pocket or tool compartment for use when you need it.

Contents

Part I—Operation

CHAPTER I— <i>Controls and Instruments</i>	9
Locks—Ignition switch lock—Gasoline gauge—Temperature indicator—Throttle control—Spark control lever—Carburetor enriching control—Carburetor heat control—Starter pedal—Oil pressure gauge—Clutch pedal—Transmission control—Brakes—Speedometer—Ammeter—Lighting switch.	
CHAPTER II— <i>Driving</i>	21
Driving speed when car is new—Danger of running engine in closed garage—Coasting—High compression cylinder heads—General driving suggestions—Don'ts for general operation.	
CHAPTER III— <i>Equipment</i>	26
Windshield and ventilation—Windshield cleaner—Rear vision mirror—Cigar lighter—Clock—TOP AND SIDE CURTAINS—Top—Side curtains on open cars—Curtain fasteners—TOOLS—TIRES—Tire valve caps—Inflation pressure—Tire carrier—Wire wheel carrier—Disc wheel carrier—Lock for spare tires on fenders—Truing up rim—Use of jack in changing tires—Changing tires.	
CHAPTER IV— <i>Cold Weather Operation</i>	38
PREPARING FOR COLD WEATHER—Anti-freezing solutions—Capacity of cooling system—Effect of alcohol on finish—Winter lubrication—Thinning engine oil—Thinning chassis lubricant—Storage battery—Gasoline system—STARTING THE ENGINE—Carburetor enriching button—Priming the carburetor—Position of throttle hand lever—Position of spark control lever—Use of starter—Use of accelerator before engine is warm.	

Part II—Lubrication and Care

CHAPTER I— <i>Systematic Lubrication</i>	45
Necessity for lubrication—Lubrication schedule—LUBRICANTS—Engine oil—Chassis lubricant—Wheel bearing and cup grease—Fiber grease.	
CHAPTER II— <i>Engine Lubrication</i>	48
Oil circulating system—Oil level—Oil pressure—Crankcase ventilating system—Oil filter—Replacing engine oil—Generator oil cups—Timer-Distributor oil cup—Fan—Water pump—Engine rear supports.	
CHAPTER III— <i>General Lubrication</i>	55
Grease gun connections—Clutch thrust bearing—Transmission—Rear axle—Front wheels—Rear wheels—Steering gear—Speedometer flexible drive shaft—Springs—Door hardware—Cooling system—Storage battery—Shock absorbers.	
CHAPTER IV— <i>Care of Body</i>	58
Care of finish when new—Washing varnished cars—Washing Duco—Cleaning windows—Cleaning upholstery.	

CHAPTER V— <i>Care of Tires</i>	61
Result of under-inflation—Result of improperly aligned front wheels—Neglect of small cuts—Result of improperly adjusted tire chains—Result of sudden application of the brakes—Additional suggestions.	

CHAPTER VI— <i>Storing Car</i>	64
Engine—Storage battery—Tires—Body and top—Taking car out of storage.	

Part III—General Information

CHAPTER I— <i>Engine</i>	68
Important features of construction—Firing order—Main and connecting rod bearings—Cylinder heads and removal of carbon—Adjustment of valve stem clearance—Grinding valves—Chains.	

CHAPTER II— <i>Gasoline System</i>	73
General description—Operation of vacuum tank—Gasoline filter—Adjustment of carburetor—Gasoline tank gauge.	

CHAPTER III— <i>Cooling System</i>	79
Water circulation—Adjustment of fan belt—Radiator and shutters—Radiator thermostat—Water pump—Filling and draining the cooling system—Cleaning the cooling system.	

CHAPTER IV— <i>Electrical System</i>	82
GENERATION OF CURRENT—Generator—Ammeter—Thermostatic control of charging rate—Adjustment of charging rate—STORAGE BATTERY—Adding water to storage battery—Specific gravity of battery solution—Disconnecting battery—Exide depots and sales offices—STARTING MOTOR—Operation of starter—IGNITION—General description—Timer-distributor—Adjustment of contact points—Timing ignition—Spark plugs—LIGHTING SYSTEM—Lamp bulbs—Cleaning headlamp reflectors—Official approval of headlamps—Adjustment of headlamps.	

CHAPTER V— <i>Clutch and Transmission</i>	98
Clutch—Adjustment of clutch release rod—Transmission.	

CHAPTER VI— <i>Steering Gear</i>	100
Description—Adjustment of worm and sector—Adjustment of worm thrust bearings—Adjustment of sector shaft—Steering connecting rod.	

CHAPTER VII— <i>Front Axle</i>	103
Description—Stop screws—Alignment of front wheels.	

CHAPTER VIII— <i>Rear Axle and Torsion Tube</i>	106
---	-----

CHAPTER IX— <i>Wheels</i>	106
Tire balancing marks—Removing front wheel—Installing wheel—Rear wheels.	

CHAPTER X— <i>Brakes</i>	108
General description—Brake adjustment—Temporary adjustment—Adjustment of rear wheel brakes.	

CHAPTER XI— <i>Repair Parts</i>	111
Genuine La Salle parts—Uniform parts prices—Ordering new parts—Returning parts—Tires, speedometer and Clock.	

CHAPTER XII— <i>Specifications and License Data</i>	113
---	-----

PART I OPERATION

CHAPTER I

Controls and Instruments

One of the first things the driver of a new car has to do is to familiarize himself with the various controls. This applies to the experienced motorist as well as to the beginner. Although there are many points of similarity between all motor cars, there are many important differences, and it is not wise, regardless of previous driving experience, to drive a new car without fully understanding what each control is for and how to use it. In the following chapter are described the levers, pedals, instruments, and other devices used in the operation of the La Salle.

Locks

The locks on the ignition switch, the tire or wheel carrier, and, on closed cars, the doors and package compartments, are operated by the same key.

The lock number is stamped on each key, but not upon the face of the lock. The owner should make a record of the key number as soon as he takes delivery of his car, so that in the event both keys are lost, a duplicate key can easily be obtained from a Cadillac distributor or dealer.

Ignition Switch Lock

The ignition is controlled by an ignition switch lock which is located at the lower right-hand side of the instrument panel. To switch on the ignition, insert the key in the lock and turn it to the right. The barrel of the lock will then slide out about $\frac{1}{4}$ inch. To shut off the ignition and lock the switch, simply push the lock all the way in.

The ignition switch lock has been given the highest rating granted by the Insurance Underwriters and has several theft-proof features that are of interest to the car owner.

When the switch is locked it not only disconnects the ignition coil from the battery but it also "grounds" the distributor. This means that any attempt to wire around the switch or to supply ignition current from an outside source would be futile, as the current would be automatically short circuited as soon as applied.

Tampering with the cable between the lock and the timer distributor is prevented by the hardened steel conduit in which the cable is carried. The cable is also connected to the distributor by a fastening which cannot be disconnected without removing and partly disassembling the distributor.



Figure 1. The new driver should familiarize himself with the instruments and controls before attempting to drive.

Gasoline Gauge

The gasoline gauge, marked "Fuel," is the small dial at the right on the instrument panel. This gauge indicates in gallons the quantity of fuel in the tank at the rear of the car, and is operated electrically. To read from the gauge the quantity of fuel in the tank, *the ignition must be switched on.* When the ignition is switched off, the gauge does not indicate the amount of fuel in the tank.



Figure 2. The gasoline gauge is operated electrically by current from the ignition circuit.

As filling station rules forbid running the engine while the gasoline tank is being filled, on such occasions the ignition should be switched off until the engine stops and then switched on again, and left on while the tank is being filled.

If the fuel supply should give out on the road, so that the vacuum tank on the dash becomes empty, it will be necessary after refilling the gasoline tank to *prime* the vacuum tank. To do this, close the throttle and hold the starter pedal down for 20 to 30 seconds. The throttle must be closed while this is done.

Temperature Indicator

The gauge at the top of the instrument panel (Fig. 3) is a thermometer for indicating the temperature of the engine and takes the place of a temperature indicator on the radiator. The bulb end of the thermometer is inserted in the water-jacket at the rear end of the left-hand cylinder head, and is connected by a small tube to the dial on the instrument board.

The normal engine temperature after the engine becomes warm is 150° to 180°.

Throttle Control

The power and speed of the engine are controlled by opening and closing a throttle valve in the carburetor. This throttle is operated both by a hand lever and a foot pedal.

The foot pedal, or accelerator, is at the right of the brake pedal (Fig. 1).

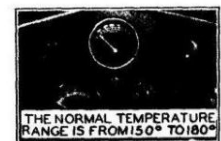

Figure 3. The temperature indicator shows the temperature of the water circulating around the cylinders.

The hand control is the upper lever above the steering wheel. Both

controls operate the same throttle; the hand lever, however, remains in the position to which it is moved, whereas the accelerator must be held down to keep the throttle open.

The normal position of the hand lever for driving the car is all the way up (at "Close"). In this position the throttle of the carburetor is open just enough to permit the engine to run at idling speed after it is warm. For starting, however, the lever should be moved approximately one-fourth the way down, and should be left in this position until the engine is warm enough to permit the lever to be returned to the idling position without stalling the engine.

In cold weather, the accelerator should not be pushed down suddenly before the engine is warm. Sudden opening of the throttle before the engine is warm causes "popping-back" in the carburetor. This should be avoided as much as possible by judicious opening of the throttle during the warming-up period. (See page 42 under "Use of Accelerator Before Engine Is Warm.")

Spark Control Lever

Correct timing of the spark in relation to the positions of the pistons is accomplished automatically by the timer-distributor, which provides for all ordinary advancing and retarding of the spark. (See page 88 under "Timer-Distributor.") A hand control is also provided for retarding the spark on certain occasions as hereafter described.

The hand control is a lever on the instrument board directly in front of the steering column. For average driving, the correct position of this lever is all the way toward "Advance." The lever should be left in this position except on the following occasions:

1. If the engine is being cranked by hand, the spark should be fully retarded by moving the lever all the way to "Retard."
2. In pulling at low speeds with the throttle well open, the spark should be retarded.
3. If, because of the accumulation of carbon in the combustion chambers, the engine knocks or "pings" on acceleration the spark may be retarded slightly. As soon as possible, the carbon should be removed so that the spark can be fully advanced.

Carburetor Enriching Control

The button at the left of the instrument panel (Fig. 4) controls a device on the carburetor for temporarily enriching the fuel mixture supplied to the engine. When starting the engine, it is necessary to

have the proportion of liquid gasoline in the fuel mixture greater than at other times, because in a cold mixture only a part of the gasoline is vaporized. Pulling out the enriching button increases the proportion of liquid gasoline to air, the normal proportions being restored when the button is released and permitted to return to its original position.

Correct use of the enriching control not only is essential to quick starting of the engine, but also has an important effect on the life of the engine. The enriching button must be pulled out far enough in starting to provide an explosive mixture quickly so that the battery is not unnecessarily discharged by useless cranking. The button must also be held out far enough during the warming-up period so that the engine will run without missing and "popping back." On the other hand, it should not be pulled out any further or held out any longer than is necessary to accomplish these results, because some of the excess liquid gasoline in the enriched mixture does not burn and washes off the oil on the cylinder walls, interfering with proper lubrication of the pistons.

If the engine still retains heat from previous running, the enriching control should not be used without first attempting to start the engine on the normal mixture. If the enriching button is pulled out for starting a hot engine the mixture may be made so rich that starting will be impossible.

The enriching button is not a priming device. It has no effect whatever on the fuel or the fuel mixture unless the engine is being cranked or is running under its own power. To have any effect, the

button must be pulled out and held partly out during the cranking operation.

Carburetor Heat Control

The lever marked "Carb. Heat" on the instrument board, directly in front of the steering column, controls the flow of exhaust gases through the jacket of the intake header which conducts the fuel mixture from the carburetor to the cylinders. This lever operates a valve at the front end of the left-hand exhaust manifold.

The normal position of the lever is as far towards "Heat On" as it will go. When the lever is in this position, the valve in the exhaust



Figure 4. The carburetor enriching control does not prime the carburetor. To have any effect, it must be held out while the starter is cranking the engine.

manifold is closed and the principal outlet for the exhaust gases from the left-hand cylinders is through the intake header jacket to the right-hand exhaust manifold. There is thus a constant flow of hot gases through the jacket of the intake header, insuring that the fuel mixture is quickly heated to the temperature at which complete vaporizing takes place.

Overheating of the mixture when driving continuously at high speeds is avoided by turning the lever to "Heat Off." When the lever is in this position, the valve in the left-hand exhaust manifold is open and the exhaust gases from the left-hand cylinders pass directly to the muffler. There is then no continuous flow of exhaust gases through the header jacket and the fuel mixture receives only just enough heat to vaporize the liquid fuel.

The lever should be turned to the "Heat On" position when starting the engine and should be carried in this position for average driving. For continuous driving at high speeds, the lever should be turned to "Heat Off." This is important, for the maximum power of the engine cannot be obtained with the valve in the exhaust manifold closed.

Starter Pedal

The starter pedal is at the right of the accelerator (Fig. 1). Pushing this pedal forward brings into action the electric motor that cranks the engine for starting. *Do not push the starter pedal when the engine is running.*

The starter pedal is only one of the controls that must be manipulated to start the engine. Unless there is an explosive mixture in the cylinders and a spark to ignite it, it is useless to crank the engine. The starter pedal should not be operated, therefore, until the necessary preliminary steps have been taken. The following, in their proper order, are the various steps that must be performed to start the engine. As each control is mentioned, reference is made to the page on which that control is explained in detail.

1. Make sure that the transmission control lever is in neutral. (Page 17.)
2. Place the spark control lever on the instrument board all the way toward "Advance."* (Page 11.)
3. Place the throttle lever about one-fourth the way down from the idling position. (Page 11.)

*If the engine is being cranked by hand, move the lever all the way to "Retard."

4. Place the carburetor heat control lever all the way toward "Heat On."

5. Switch on the ignition. (Page 9.)

6. Unless the engine is still warm, pull back the carburetor enriching button and hold it back. If the engine is still warm, do not pull back the enriching button unless the engine fails to start on the normal mixture. (Page 11.)

7. Push the starter pedal forward and hold it until the engine starts. Release it immediately as soon as the engine starts. (See below for probable causes for the engine failing to start.)

8. Let the carburetor enriching button partly in as soon as the engine starts, and all the way in as soon as the engine is warm enough to permit it. (Page 11.)

9. Note whether pressure is indicated on the oil pressure gauge and stop the engine at once if no pressure is indicated. (Page 15.)

10. Move the throttle lever up to the idling position as soon as the engine is warm enough to permit it.

In cold weather, disengage the clutch before pressing down the starter pedal, and hold it down during the cranking operation. This relieves the starter of the necessity of turning the transmission gears, which are immersed in lubricant. The additional load is small in warm weather when the lubricant is thin, but in cold weather the power required to turn the gears through the thickened lubricant adds unnecessarily to the demand upon the battery.

What to Do if the Engine Fails to Start.

If the engine fails to start after being cranked for a few seconds, release the starter pedal and investigate the following possible causes:

The ignition may be switched off.

There may be no gasoline in the tank at the rear of the car.

There may be no gasoline in the vacuum tank on the dash. If the vacuum tank should be empty, prime it by closing the throttle, and, with the ignition switched off, holding the starter pedal down for 20 to 30 seconds. The throttle *must be closed* while this is done. Then open the throttle, switch on the ignition, and try again to start the engine in the usual manner.

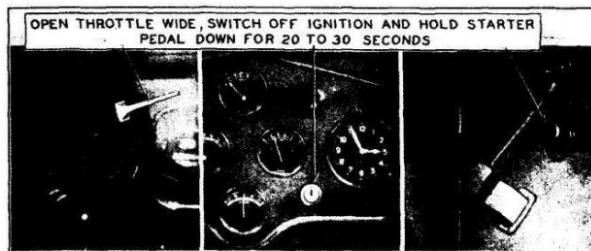

Figure 5. What to do when the engine refuses to start because the carburetor is flooded.

The carburetor may be flooded by unnecessary use of the enriching device when the engine is warm. To get rid of this surplus gasoline in the carburetor, *open the throttle wide*, and, with the ignition switched off, hold the starter pedal down for 10 to 15 seconds. Then return the throttle lever to the usual position for starting, switch on the ignition and try again to start the engine.

Oil Pressure Gauge

The small dial at the left on the instrument panel (Fig. 6) is the oil pressure gauge. This gauge does not indicate the quantity of oil in the engine. It indicates only the pressure under which the oil is forced to the engine bearings.

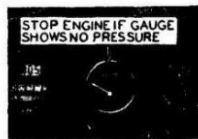

Figure 6. The oil pressure gauge does not show how much oil is in the engine—it shows pressure only. The pressure when the engine is idling should be 7 to 10 pounds.

When the engine is not running, the pointer on the oil pressure gauge should remain at zero, but as soon as the engine is started and as long as it runs, the gauge should show pressure. If the gauge does not show pressure when the engine is running, stop the engine at once and determine the cause. Serious damage may be done if the engine is run without oil pressure. (See page 49 under "Oil Pressure.")

The amount of pressure indicated by the gauge depends upon the speed of the engine and the viscosity of the oil. At idling speed with fresh oil of the correct viscosity, the oil pressure after the engine is warm

should be 7 to 10 lbs. Before the engine is warm the pressure will be higher. After the oil has become thin from use, the pressure will be lower. These are normal variations from the standard and do not indicate need for attention.

Clutch Pedal

The clutch pedal is the left-hand pedal. When this pedal is in its normal or released position, the clutch is engaged. The flywheel of the engine is then coupled to the transmission by a disc clutch under the pressure of twelve springs. When the clutch pedal is pushed down, these springs are compressed and the clutch discs separate. The clutch is then disengaged and the flywheel, if the engine is running, revolves independently of the transmission.

The clutch has two uses: First, to enable the car to be started gradually and without jerk or jar; second, to permit shifting of the transmission gears. The operation of the clutch pedal is discussed in connection with the transmission control on page 17. Further comment is unnecessary at this point except the following suggestions to the driver:

Do not drive with the foot resting on the clutch pedal. The La Salle clutch operates so easily that even the weight of the driver's foot may unintentionally cause the clutch to slip.

Do not form the practice of disengaging the clutch whenever the brakes are applied. Most occasions for use of the brakes require only slowing down without stopping or even shifting gears. A skilled driver will not touch the clutch pedal until the car is just about to stop or until he is about to shift to a lower gear. It is a mistaken idea that applying the brakes with the clutch engaged is more severe on the brake lining. The

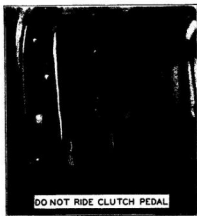

Figure 7. A good driver uses the clutch pedal only when shifting gears or about to stop.

opposite is actually the case, proof of which is in the fact that in coasting down grades the resistance of the engine is used to assist the brakes in controlling the car speed.

It will be observed in operating the clutch pedal that the pedal offers almost no resistance until it has been moved about one inch. It is at this point that it actually begins to disengage the clutch. It is important that the pedal have this "lost motion." If the full pressure of the clutch springs is felt just as soon as the pedal is moved, the rod should be readjusted as directed on page 97. Failure to make this adjustment will result in the clutch slipping.

Transmission Control

The La Salle transmission has three forward speeds and reverse. It is controlled by a lever, the handle of which describes the letter "H" as it is moved from one position to another. It should be observed by those who have driven other makes of cars, that, although most cars

have the conventional H-type of transmission control, all these cars do not have the same positions of the lever. The driver should study Fig. 8 carefully, and if the various positions of the lever are different from those to which he has been accustomed, he should master this arrangement before attempting to drive.

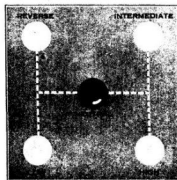

Figure 8. The positions of the control lever form the letter "H."

No attempt can be made here to teach the beginner the technique of gear shifting. The beginner should secure individual instruction from the distributor or dealer from whom the car was purchased and who will be glad to give this instruction. The following suggestions, however, may be of assistance.

Before shifting from neutral to low to start the car, wait a few seconds after disengaging the clutch in order to give the gears a chance to stop "spinning." The faster the idling speed of the engine the longer it will take for the gears to come to rest. For this reason it is best to have the throttle lever set as near the closed position as possible without stalling the engine.

When shifting *up*, from low to intermediate or from intermediate to high, there should be a short period of hesitation in neutral before completing the shift. This period will be shorter or longer according to the speed of the car when the shift is made. It is necessary to learn from practice just how long to wait.

When shifting back from high to intermediate there should be no hesitation whatever in neutral. The lever should then be moved as quickly as possible and the car should not be traveling faster than 15 miles per hour.

There are times when it is desirable to be able to shift from high to intermediate at higher car speeds. It is possible to do this by the following method which is called "double de-clutching.":

Disengage the clutch and shift the transmission control lever at once to neutral. Re-engage the clutch, at the same time accelerating the engine; then disengage the clutch again and instantly shift to intermediate, after which re-engage the clutch. The speed to which the engine should be accelerated while the transmission control is in neutral depends upon the speed at which the car is traveling when the shift is made.

It is not recommended that the driver attempt the double de-clutching method until he has become expert in shifting from high to intermediate in the usual manner at lower speeds.

Make a practice of shifting the transmission control to intermediate or even to low before commencing the descent of steep grades. The reason for this is explained on page 21, where will also be found further suggestions for coasting.

Do not make any of the following shifts when the car is moving:

From reverse to any forward gear.

From any forward gear to reverse.

From high gear to low gear.

From intermediate to low gear (except when the car is moving very slowly.)

Brakes

The foot brakes, which consist of external brake bands on the rear wheels and internal bands on the front wheels, are operated by the right-hand pedal.

As the brake lining wears, the pedal must be pushed farther down to apply the brakes. Do not wait until the pedal goes all the way to the floor board before having the brakes re-adjusted. Re-adjustment is recommended as soon as the pedal must be pushed down to within one inch of the floorboard.

The hand brakes, which are internal brakes on the rear wheels, are operated by the hand lever at the right of the transmission control lever.

Speedometer

The lower dial of the speedometer, which is for recording "trip" mileage, can be reset to zero by pushing up and turning the knurled stem back of the instrument board.

Across the speedometer cover glass and below the total mileage dial is a strip of black celluloid on which are two white spaces. These spaces are for the lubrication notice described on page 46 in connection with the lubrication schedule. Use this notice in accordance with the schedule.

An automobile repairman should never be permitted to attempt to adjust or repair the speedometer head or to replace the glass. This work can be done only by men experienced in speedometer work and only with special machinery and tools. If the speedometer head is removed, handle it as carefully as a fine watch. The speedometer head may easily be damaged by rough handling.

Ammeter

The lower dial on the instrument panel (Fig. 9) is the ammeter, which measures the electric current flowing to or from the battery at all times except when the starter is cranking the engine. When current is flowing from the battery, the ammeter shows a reading on the side marked "Discharge;" when current is flowing to the battery, the ammeter reading is on the "Charge" side.

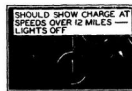

Figure 9. The ammeter indicates the amount of electrical current flowing to or from the battery.

The ammeter should indicate on the "Charge" side most of the time. Otherwise, more current will be taken out of the battery than is put into it and the battery will eventually become fully discharged. The exact amount of current that should be indicated by the ammeter at any time depends upon various conditions, which are explained on page 83.

Ordinarily, when no lights are in use, the ammeter should show "Charge" as soon as the car is running ten or twelve miles per hour in high gear. If the ammeter should show "Discharge" with all lights off, either when the engine is not running or when the car is running more than twelve miles per hour, the cause should be investigated.

Lighting Switch

The lighting switch control is at the upper end of the steering column in the center of the steering wheel. The lever has three positions besides "Off." These positions are marked respectively: "Parking," "Down," and "Up." The corresponding combinations of lights are as follows:

Parking—Parking lights (dim), and rear lamp.

Down—Headlamp lower beams (bright), and rear lamp.

Up—Headlamp upper beams (bright), and rear lamp.

The headlamp bulbs have two filaments, one above the other, instead of the customary single filament. Both filaments are of the same candlepower (21), but because they are located in different positions with respect to the reflector, the beam of light from one filament is projected at a different angle from the other. When the switch lever is at "Up," one set of filaments is lighted and the beams are projected straight ahead, illuminating the road at a distance. When the lever is at "Down," the other filaments are lighted and the beams are projected down at an angle, illuminating more brightly the road directly in front of the car.

The practice to be followed by the driver in using this double-beam feature of the headlamps will depend upon local regulations. In general, it is expected that the upper beams will be used except on the following occasions: When passing a vehicle approaching from the opposite direction, when rounding a sharp curve and when topping the crest of a hill. On these occasions and at other times when illumination is desired directly in front of the car, the lower beams should be used. For a further description of the headlamps, see page 93.

The instrument lamps are controlled by a separate switch at the left-hand end of the instrument board.

CHAPTER II

Driving

THE preceding chapter of the Manual has aimed to familiarize the driver with the controls and instruments used in operating the car. Actual skill in driving is, of course, more than knowledge of and familiarity with these individual devices. It is not the purpose of this Manual to discuss all phases of driving, but there are a few matters of sufficient importance to La Salle owners to warrant devoting a chapter to them.

Driving Speed When Car Is New

The parts of the La Salle car are machined and ground to secure the most accurate fit and the finest finish. Proper functioning of the assembled mechanism is further assured by testing the engine and chassis both on shop dynamometers and on the road. Nevertheless, it is not possible by manufacturing processes and tests to give to bearing surfaces the fine polish that results from continued operation at moderate speeds and loads.

Until a new car has been driven far enough to produce this effect on the bearing surfaces, the car should not be driven at high speeds. Moderate driving during the first five hundred miles will increase the life of the car more than enough to repay any inconvenience. Manufacturers of locomotives and stationary steam engines have always recognized the necessity for an initial "running in" period.

Danger of Running Engine in Closed Garage

Every person having to do with the operation or care of a motor car should be warned of the danger that attends running the engine while the car is in a small closed garage.

Carbon monoxide, a deadly poisonous gas, is present in the exhaust of all internal combustion engines. Most people are already familiar with carbon monoxide in the form of illuminating gas, or in the gas produced by furnaces and stoves when insufficient air is supplied to give complete combustion. But illuminating gas and coal gas have an unpleasant odor, which serves as a warning, whereas carbon monoxide, as produced in the internal combustion engine, is colorless, tasteless, and almost odorless, so that the victim may be overcome before he is aware of the danger.

When the engine exhausts into the open air, the carbon monoxide is so diluted that it has no effect. It is when the engine is run for a time in a closed room that the proportion of carbon monoxide in the air may increase to the point at which continued breathing of it would be fatal. The United States Public Health Service advises that the average automobile engine warming up in a single-car garage will give off enough carbon monoxide in three minutes to endanger life.

Proper precaution must be taken in cold weather when the natural tendency is to keep the garage doors and windows closed. The practice of letting the engine warm up in a closed garage before opening the doors is unsafe. The risk is made greater by the fact that the enriching of the mixture by manipulation of the carburetor enriching device increases the amount of carbon monoxide formed.

Coasting

To coast *on the level*, simply release the accelerator pedal and disengage the clutch. If coasting to a stop, the transmission control may also be shifted to neutral and the clutch re-engaged.

In coasting *down grades*, however, it is recommended that the transmission be left in gear and the clutch engaged. With the throttle in the idling position, the car is thus made to drive the engine, the resistance of which assists the brakes and saves wear on the brake lining. It must be remembered that the brakes are subjected to much more severe use on grades than on the level because gravity acts continuously, whereas on the level the brakes need absorb only the momentum of the car. Even on slight grades, coasting with the transmission in neutral or the clutch disengaged is not advisable. On any grade steep enough to warrant coasting, it is worth while to save the brakes as much as possible by utilizing the braking effect of the engine.

Ordinarily, the resistance offered by the engine when the transmission is in high is sufficient to control the speed of the car, supplemented by moderate use of the brakes. On steep grades, however, the transmission control should be shifted to intermediate or even to low if the grade is very steep. Shifting should always be done before commencing the descent of the grade, because, after the car has once gained speed, considerable braking may be necessary to slow down to the speed at which the shift can be made easily.

Do not switch off the ignition when coasting with the car driving the engine. Contrary to a common impression, this does not appreciably increase the resistance and is likely to cause damage to the engine.

Even with the throttle closed, some fuel is admitted to the cylinders, and if this is not burned it condenses on the cylinder walls and washes off the oil by which the pistons are lubricated.

High Compression Cylinder Heads

Some La Salle cars are equipped on special order with what are known as "high compression" cylinder heads. These are cylinder heads in which the space into which the fuel mixture is compressed just before it is ignited is so proportioned that a higher pressure is obtained than with standard cylinder heads. High compression cylinder heads can be identified by the letters "HC" in a circle cast on the outer surface of the heads.

High compression cylinder heads enable the engine to develop slightly more power, but they can be used only with anti-knock fuel (except at high altitudes.) The owner of a car equipped with these heads must therefore understand this limitation and arrange his fuel supply accordingly.

If, in an emergency, anti-knock fuel is not available and it is necessary to use regular fuel, this can be done but it is necessary to retard the spark to prevent spark-knock. The use of regular fuel with high-compression heads should be resorted to only in an emergency or at high altitudes.

An engine with high compression cylinder heads also requires special ignition timing. This is understood at Cadillac service stations; if it should ever be necessary to have the ignition timing checked elsewhere, instructions should be given to time the spark to take place $\frac{1}{2}$ inch (on the flywheel) ahead of center when the manual control is fully advanced.

General Driving Suggestions

Road and traffic laws vary greatly in different localities. It is unfortunately impossible to set down a complete list of rules that may be followed in all parts of the country. The following are some of the rules that are universal in practically all parts of the United States.

In meeting a vehicle going in the opposite direction pass to the right.

In overtaking a vehicle going in the same direction pass to the left.

Always stop with the right-hand side of the car next to the curb. If it is necessary to turn the car around to do this, it should be done.

Never turn around or turn off on another road without making absolutely certain that there is no other vehicle directly behind.

Do not cross street car or steam railroad tracks without making certain that it is absolutely safe to do so. At any railroad crossing that is on an upgrade or which for any reason must be approached very slowly, it is a wise precaution to shift to intermediate gear before crossing because the car can thereby be accelerated more quickly, if necessary.

In crowded traffic do not apply the brakes suddenly unless it is absolutely necessary. A vehicle following may not have brakes as efficient as La Salle four-wheel brakes.

On wet asphalt streets or slippery roads do not disengage the clutch when applying the brakes. Also, do not apply the brakes suddenly unless it is absolutely necessary. La Salle four-wheel brakes minimize the possibility of skidding under these conditions, but their effectiveness should not induce anyone to drive less carefully.

Slow down in passing vehicles going in the opposite direction.

Never take a chance.

Don'ts for General Operation

Don't fail to change the engine oil as frequently as recommended.

Don't fail to release the carburetor enriching button as soon after starting as possible.

Don't fill the lubricating system of the engine alone and neglect to lubricate all other parts of the car.

Don't neglect the lubrication of any part of the car.

Don't run the car at sustained high speed when it is new.

Don't allow the clutch to engage suddenly.

Don't prime the carburetor too much.

Don't allow the vent hole in the gasoline tank filler cap to become stopped up.

Don't attempt to shift from neutral to any gear, or from one gear to another gear, without first disengaging the clutch.

Don't attempt to shift from the reverse gear to any other gear when the car is moving.

Don't attempt to shift from any forward gear to the reverse gear when the car is moving.

Don't attempt to shift from the high gear to the low gear when the car is moving.

Don't attempt to shift from the intermediate gear to the low gear when the car is moving, unless it is moving very slowly. Ordinarily it is best to stop the car altogether.

Don't switch off the ignition when coasting with the car driving the engine.

Don't push the starter pedal when the engine is running.

Don't turn the steering gear when the car is standing. This is not only unnecessary but is also bad practice. The front wheels pivot more easily if they are rotating.

Don't fail to investigate any unusual sound which may develop in the car. The car should be regularly inspected at a Cadillac service station.

Don't neglect to inspect the level of the acid solution in the storage battery every 1000 miles and in summer every 500 miles, or at least every two weeks, and add distilled or other approved water if necessary. *Never add anti-freeze to the battery.*

Don't turn corners at high speed.

Don't neglect to keep the cooling system filled to the recommended level (page 39).

Don't drive fast or attempt to stop suddenly on wet pavements.

Don't attempt to start the engine with the switch turned off, or without gasoline in the tank.

Don't neglect to keep the tires inflated properly.

Don't race the engine when it is not driving the car. There is no worse abuse.

CHAPTER III

Equipment

The controls and instruments used in driving have already been described. In addition to these the car is equipped with various devices which are for the convenience and comfort of the occupants, and are used only as occasion demands. It is suggested that the driver anticipate his use of such equipment by becoming familiar at once with the directions contained in this chapter.

Windshield and Ventilation

CLOSED CARS—La Salle closed cars are equipped with a one-piece windshield, which can be moved up and down. Movement of the glass is controlled by a handle above the windshield. To raise the glass, the handle should be turned clockwise, and to lower the glass the handle should be turned counter-clockwise.

For ventilation under the cowl, the windshield should be raised not more than one inch so that the lower edge of the glass is still below the ledge over the instrument board. With the windshield in this position, air is deflected into the driving compartment through an opening in the cowl just forward of the instrument board. If desired, the wind-

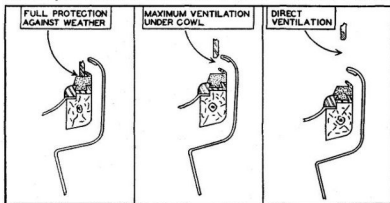

Figure 10. The closed car windshield has three positions: the position shown in the center is best for warm weather.

shield can be raised above the level of the ledge over the instrument board, and air will then enter directly into the car. In this position, however, less air will be forced down under the cowl. (Fig. 10.)

Cowl ventilators are also provided on the closed cars to supplement the ventilation provided by the windshield. These ventilators are at

(26)

the sides of the cowl compartment and open toward the rear, serving as outlets for the air entering under the windshield.

OPEN CARS—La Salle open cars are equipped with two cowl ventilators which are operated by levers just in front of the instrument board.

The open car windshield is in one section, which is pivoted at the lower corners. To fold the windshield outward, loosen the wing nuts and tighten them again after the windshield is in the desired position.

Windshield Cleaner

The windshield cleaner is operated by the suction or vacuum in the passages between the carburetor and the engine.

The cleaner is controlled by a knurled button on the left-hand end of the instrument board. When the button is turned clockwise as far as it will go, the cleaner is shut off. To start the cleaner, turn the button counter-clockwise. On open cars, the control button is located at the cleaner itself.

Rear Vision Mirror

The rear vision mirror may be adjusted by the driver to suit his preference after loosening the clamp screws that hold the mirror to its supporting bracket.

Cigar Lighter

The car is equipped with a cigar lighter with flexible cord attached to the back of the instrument board.

To use the cigar lighter, pull it out from the instrument board and press the switch button on the side of the shield, holding it down until the cigar or cigarette is lighted. To light a pipe, remove the nickel plated shield by turning it slightly counter-clockwise and pulling it straight off.

Clock

The clock has an eight-day movement and is wound in the same manner as a watch. The stem is to the right of the clock back of the instrument board.

Top and Side Curtains

Top

Illustrated directions for folding the top on open cars are given in Fig. 11.



Fig. 11a

Remove the nickel-plated caps on the sockets for the top supports and install the supports by pushing them into the sockets and tightening the cap screws.



Fig. 11b

Detach the side quarter curtains from the bow sockets and fold the curtains back against the rear curtains. Unscrew the thumb screws over the windshield supports and push the top up so that the clamps are free from the supports.



Fig. 11c

Fold the front part of the top back toward the rear. Do not gather the top deck between the bows but let it fall back clear of the top. Then fold the deck neatly and tuck it under the bows.

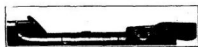

Fig. 11d

Draw the dust boot over the folded top. It is secured by four straps at the open corners. These straps should be fastened around the bows and pulled tight to keep the boot smooth. The boot should look like this when properly strapped in place.

Figure 11. Folding the top

Side Curtains on Open Cars

The side curtains, with which the open cars are equipped, are carried in an envelope provided with cloth partitions to prevent rubbing and chafing. The side curtains are stowed in a special compartment back of the front seat.

The Phaeton curtains are in six sections, each of which is marked to indicate its position, as "Left Front," "Right Center." The front and center sections on both sides are each provided with a rod, the lower end of which fits in a socket in the top of the door. When a curtain is folded for stowing, this rod is parallel with the bottom of the curtain as shown in Fig. 12. Before the curtain can be attached to the door, the rod must be moved to the position shown by the dotted lines. The upper end of the rod is slotted to engage with the stiffener that runs along the upper edge of the curtain.

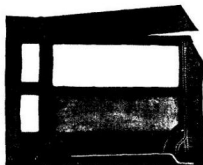

Figure 12. Side Curtain

The folding flap on the door curtains has the upper rear corner cut off diagonally. This is to permit its being tucked through on the outside when the flap is closed. By tucking the flap this way, the wind is prevented from blowing in at the rear of the flap.

The rear sections should be applied first, followed by the center and front sections. The rear sections should be fastened to the rear bows under the side flaps of the permanent rear curtains.

Before stowing the curtains, they should be dry and clean.

Curtain Fasteners

The curtain fasteners used on the top and side curtains are of three different types. The type used on the side curtains at the points where they fasten to the body is illustrated in Fig. 13b. To release this type of fastener



(a) (b) (c)
Figure 13. Three types of fasteners are used on the top and side curtains. The way to unfasten each is shown above

press in on the small plunger or button in the center of the fastener.

At other points the fastener as illustrated in Fig. 13a is used. When this type of fastener is snapped on its stud, it becomes locked on three sides. To release this type of fastener, it must be lifted on the side that is not locked. This side is indicated by the small projection to which the arrow points in Fig. 13a. This type of fastener cannot be released by lifting it at any other side.

The remainder of the fasteners used on the top and side curtains are of the usual glove type. (Fig. 13c).

Tools

The compartment for the tools is under the front seat. The tools comprising the standard equipment are listed below and are illustrated in Fig. 14. Items listed opposite Nos. 24, 25, 26, 27 and 28 are not illustrated.

- | | |
|--|---|
| 1. Open end wrench $1\frac{1}{8}$ - $\frac{3}{8}$ | 15. Monkey wrench |
| 2. Open end wrench $\frac{3}{4}$ - $\frac{1}{4}$ | 16. Hand starting crank |
| 3. Open end wrench $\frac{5}{8}$ - $\frac{1}{8}$ | 17. Hub cap wrench (Fig. 14 shows wrench for wire wheels) |
| 4. Open end wrench $\frac{1}{2}$ - $\frac{1}{4}$ | 18. Brake adjusting wrench |
| 5. Distributor wrench (with gauge for adjusting timer contact points and spark plugs). | 19. Spoke wrench (Wire wheels only) |
| 6. Distributor wrench (plain) | 20. Grease gun |
| 7. Center punch | 21. Wheel bearing wrench (Wire wheels only) |
| 8. Cold chisel | 22. Jack handle |
| 9. Small screw driver | 23. Jack |
| 10. Large screw driver | 24. Rim wrench (Wood wheels only) |
| 11. Hammer | 25. Brace wrench (Disc wheels only). |
| 12. File | 26. Tool bag |
| 13. Pliers | 27. Lubrication chart |
| 14. Oil can | 28. Operator's Manual |

Tires

Tire Valve Caps

The valve caps used with some makes of tires are a combination dust and valve cap. This type of cap can be removed and installed without screwing the cap the entire length of the threads on the valve stem.

To remove one of these valve caps, turn it two or three turns counter-clockwise. This loosens the sliding nut inside the cap. (Fig. 15.) Next, pull the cap up as far as it will go. Then remove the cap by unscrewing it the rest of the way.



Figure 14. The tools are carried in the compartment under the front seat. See page 30 for the name and use of each tool.

To install a valve cap, place the cap over the valve stem and turn it a few turns clockwise to engage the threads in the sliding nut. If the sliding nut is too far inside the cap to be reached by the valve stem, shake the nut down by tapping the bottom of the cap on some solid object. When the valve stem has been started in the sliding nut, push the cap down over the stem as far as it will go. Then turn the cap until it locks tightly.



Figure 15.
Tire valve cap

Inflation Pressure

For normal driving, the tires should be inflated to a pressure of 40 lbs. per square inch. The inflation pressure should be checked at least weekly and should not be permitted to drop more than 5 lbs.

On cars driven at high speeds, the front tires should be inflated to 50 lbs. or higher if necessary. *This is important.*

Tire Carrier (Wood Wheel Equipment)

To remove the spare tire from the carrier, proceed as follows: Insert the key in the lock and turn it to the right, holding the lock itself

from turning with the thumb of the left hand.

Remove the lock, using the key as a handle.

Unscrew the clamping screw with the wrench furnished in the tool equipment.

Let the clamp drop down, taking care not to lose the clamping screw.

Remove the tire with rim by pulling it out at the bottom and then lifting it off the carrier.

To place a tire and rim on the carrier reverse the above order. After tightening the clamping screw, snap the lock into place.

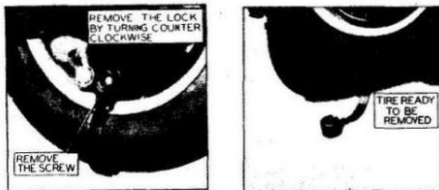

Figure 16. The spare tire can be removed after the clamp is unlocked in this manner.



Figure 17. After unlocking the lock, the large nut holding the wire wheel can be unscrewed with the hub cap wrench.



Figure 18. The clamp over the disc wheel can be unscrewed by hand after it is unlocked.

Wire Wheel Carrier

To remove the spare wire wheel from the carrier, first unscrew the dust cap which protects the lock. Insert the key in the lock and turn it to the right. Then unscrew the large nut, using the hub cap wrench. The wheel can then be taken off the carrier.

When installing the wheel on the carrier, tighten the nut as far as it will go. Then insert the key and turn it to the left.

Disc Wheel Carrier

To remove the spare disc wheel, unscrew the small dust cap and unlock the carrier in the same way as for the wire wheel. Then unscrew the large clamp, removing the large dust shield. The wheel can then be taken off the carrier, after unscrewing the cap nuts by which it is fastened.

When installing a wheel on the carrier, tighten the clamp and lock it in place by turning the key to the left.

Lock for Spare Tires on Fenders

When the spare tires or wheels are carried on the fenders, a lock is provided for each wheel or tire. This lock is fastened to the fender and must be removed before the tire or wheel can be removed. To remove the lock insert the key and turn it to the right. The lock can then be lifted out.

When mounting spare tires in fenders, they should be partly deflated before being put in the fender well, and should be fully inflated after they are in position. By following this method a snug fit is secured, and the tires or tire covers are prevented from chafing.



Figure 19. When spare tires are carried on the fenders, the lock must be removed from the fender before the spare tire can be removed.

Truing Up Rim

If a rim on a wood wheel does not run true, it may be trued up in the following manner: Rotate the wheel slowly and mark the part that runs farthest out from the face of the wheel. Loosen slightly the nuts diametrically opposite the mark and then tighten the nuts on the marked side. Test the wheel again, and if it still does not run true, repeat the operation.



Use of Jack in Changing Tires

When a tire is "flat," the axle is not far enough above the ground to permit placing the jack directly under the axle. It is then necessary to make use of the adjustable shoulder which engages with teeth on the side of the jack.

If a front wheel is to be raised, the jack should be so placed that the adjustable shoulder is under the axle. If a rear wheel is to be raised, the jack should be placed so that the adjustable shoulder is under the bracket shown in Fig. 20.

Changing Tires

If an inflated spare tire is always carried on the spare rim or wheel, the driver will seldom or never have to disassemble a tire from the rim. In case of tire trouble, it is then merely necessary to remove the rim or wheel with the flat tire and install the spare in its place. Illustrated directions for performing this work on wood, wire and disc wheels are given on pages 35, 36 and 37.



Figure 20. To jack up the car it is necessary to have the jack in the proper position under the axle.



Figure 21a. Jack up the wheel until the tire clears the ground. Remove the dust cap and clamping nut from the valve stem. Remove the six rim clamps, unscrewing them with the brace wrench supplied in the tool kit.



Figure 21b. Rotate the wheel until the valve stem is at the top, and pull the bottom of the rim away from the wheel.



Figure 21c. Then rotate the wheel until the valve stem approaches the bottom, when the rim and tire will roll free from the wheel and can be removed without lifting.

To mount a rim, rotate the wheel until the hole for the valve stem is in the position shown in the last illustration. Insert the valve stem and rotate the wheel, which will carry the rim with it, until the valve stem is at the top. Then push the lower part of the rim into place. Install the rim clamps over the rim and turn the nuts partly down. Go over the nuts again and tighten them firmly. Install the valve stem clamping nut and the dust cap. Be sure the clamping nut is tight.

Figure 21. Changing Rims (Wood wheels)



Figure 22a. Jack up the wheel until the weight of the car is off it, but with the tire still dragging. Place the hub cap wrench on the cap with the cam lever lowered, engage the sliding barrel puller in the slots and turn the puller one-quarter turn either way.



Figure 22b. Raise the lever up and over, thus drawing out the sliding barrel of the hub cap. If the barrel does not withdraw easily, tap the end of the wrench back and forth. This will release the pressure on the teeth of the sliding barrel and allow it to disengage.



Figure 22c. Loosen the hub cap by striking the wrench a few times with a hammer. (The hub caps are marked with arrows showing the direction in which they screw on and off.) Then jack up the wheel, unscrew the hub cap and pull the wheel off the inner hub. Never attempt to remove the hub cap without the weight of the car on the wheel.

In installing the wheel, see that it is set up snugly on the corrugations on the inner hub. Hub caps are marked either "Right Side" or "Left Side" and must always be installed on the proper side. Start the cap by hand, taking care not to cross the threads. Then apply the hub cap wrench and disengage the sliding barrel as directed above. Securely tighten the cap, striking the end of the wrench with a hammer a few times. Lift up the cam lever. If the sliding barrel does not automatically engage, tighten the cap farther.

Figure 22. Changing Wire Wheels

Note: The nuts on the right-hand wheels are marked R; those on the left are marked L. All nuts screw off in the direction the wheels rotate when the car is going backward, and on in the forward direction.



Figure 23a. To remove a front wheel, jack it up until the weight of the car is off it, but with the tire still touching. Then loosen the cap nuts around the wheel hub with the brace wrench in the tool kit. Jack the wheel up further, unscrew the nuts and remove the wheel. In removing a rear wheel, set the hand brake and jack the wheel all the way up.



Figure 23b. In mounting disc wheels, use the rear end of the brace wrench as a pilot bar.

To mount a front wheel, bring it up close to the hub and pass the pilot bar through a lower hole and over a lower stud. Lift with the bar, and guide the wheel with the other hand. The weight of the wheel will keep the hub from turning, and the wheel will slip easily into place.



Figure 23c. To mount a rear wheel, set the hand brake and put the pilot bar through an upper hole and over an upper stud.

In either case, several nuts should be started by hand before the pilot bar is removed. The nuts should not be tightened in rotation. After tightening one nut, tighten the nut directly opposite. In this way the first two nuts center the wheel and insure a good fit. The nuts need not be as tight as they can be forced. They should be only moderately tight.

Figure 23. Changing Disc Wheels

CHAPTER IV

Cold Weather Operation

The La Salle car is an all-season car and no owner need hesitate to make full use of his car in severe winter weather as well as at other times. Satisfactory operation in freezing weather, however, depends upon having the car prepared for cold weather and in giving it the special attention which is required at that time. In this chapter has been grouped all the information relating to care and operation of the car during cold weather. It should be reviewed just prior to the beginning of the winter season.

Preparing for Cold Weather

Anti-Freezing Solutions

In freezing weather, the water in the cooling system must be replaced with some solution that has a lower freezing temperature than that of water. A solution of denatured alcohol and water is recommended.

Before putting anti-freeze in the radiator, the cooling system should be thoroughly cleaned by flushing (see page 81). It is also important to inspect the hose connections and see that they are all in good condition, so that loss of anti-freeze by leakage will be avoided.

The strength of an alcohol solution must be periodically tested with a hydrometer. Alcohol vaporizes more rapidly than water and the loss by evaporation must be replaced at frequent intervals or the weakened solution will afford little protection against freezing. Care must also be taken not to let an alcohol solution get on the finish of the hood or radiator.

The following table gives the freezing temperature and specific gravity of solutions of denatured alcohol and water:

Lowest Temperature Expected	Per cent by Volume	Specific Gravity (at 60° F.)	Qts. Alcohol required to make $\frac{3}{4}$ gals. solution
+10° F.	30	.9668	6 $\frac{1}{4}$
0° F.	38	.9567	8
-10° F.	45	.9485	9 $\frac{1}{2}$
-20° F.	51	.9350	10 $\frac{3}{4}$
-30° F.	57	.9260	12

(38)

Patented substitutes should not be used unless tested and approved. Cadillac distributors and dealers should be consulted as to the suitability of an anti-freeze or inquiry may be made to the factory Service Department. Solutions containing calcium chloride or other ingredients injurious to the metal parts of the cooling system must never be used.

Capacity of Cooling System

The capacity of the cooling system is five and one-quarter gallons when filled to the proper level. It is not necessary to add liquid to the radiator whenever the level falls below the filler. There is sufficient liquid in the cooling system if the upper tank is half full, and any liquid in excess of this is usually forced out through the overflow pipe as soon as the engine becomes warm. When water is used, any loss from this cause is of little consequence, but in winter to conserve anti-freeze it is important to avoid adding more liquid than is necessary.

Effect of Alcohol on Finish

Strong solutions of alcohol have a harmful effect on the finish. In adding pure alcohol or solutions containing 50 per cent or more alcohol, extreme care must be used not to let the liquid spatter or spill. A funnel and a pouring vessel with a suitable spout are necessary. Especially avoid pouring cold alcohol into very hot water. The effect of this is to make the mixture foam up and possibly bubble over on the finish.

Winter Lubrication

Lubrication of the car requires special attention in winter, not only to insure proper lubrication of the moving parts, but to secure the same ease of operation in starting, steering and shifting gears as during warmer weather.

Contrary to popular impression, this does not mean the use of special winter lubricants. The lubricants approved by Cadillac engineers and sold by Cadillac distributors are year-round lubricants. It is not necessary therefore, to change the engine oil or the lubricant in the transmission or rear axle when cold weather approaches. It is merely necessary to thin these lubricants with kerosene. Authorized Cadillac service stations are prepared with full information as to the amount to be added and the conditions under which it is to be added.

The temperature at which thinning of the engine oil is necessary depends upon the oil used, but with most of the approved oils, some

kerosene should be added as soon as the temperature drops to freezing. From one to three quarts of kerosene are necessary, one quart being plenty for temperatures around freezing while three quarts will be required at 10° below zero.

After the oil is once thinned, additional kerosene does not ordinarily need to be added until the engine oil is changed at the usual 2000-mile interval. The fresh oil must then be thinned. However, on a long hard drive some of the kerosene will be driven out by evaporation. After such a drive, kerosene should be added to replace that which has evaporated.

When thinning the oil in the engine a small amount of kerosene should also be added to the oil in the fan reservoir.

The lubricant in the transmission, rear axle and steering gear should also be thinned as soon as the weather is so cold that the transmission gears are hard to shift. If a sufficient amount of kerosene is added to provide for the lowest winter temperature expected, it will not be necessary to add kerosene again thereafter during the winter. If ten per-cent kerosene is added, this will take care of temperatures down to ten below zero.

Storage Battery

The electrical system of an automobile has much more to do in winter than in summer. The engine is harder to crank and must usually be cranked longer before it starts. The lights are also used to a much greater extent than during the long days of summer. All this means that the battery must be ready for increased demands.

It is therefore a good plan in preparing for the winter season to see that the battery is well charged to begin with, that the battery connections are clean and tight and that the charging rate of the generator is sufficient.

Gasoline System

The carburetor on the LaSalle engine has automatic compensation for temperature. Nevertheless it is a good plan to check the carburetor adjustment when cold weather arrives. This inspection should give special attention to the carburetor choke control to make sure that the enriching device at the carburetor is fully effective when the choke button is operated.

In warm weather a small amount of water in the gasoline has little or no effect on the running of the engine. In freezing weather, however, even a small amount of water may freeze and stop the entire flow of fuel to the carburetor.

One of the things to be done in preparing for winter weather, therefore, is to clean the gasoline filter and the sediment chambers in the gasoline system. (See page 75.)

Starting the Engine

Carburetor Enriching Button

The first difference between starting the engine in cold weather and starting the engine in warm weather is in the greater use of the carburetor enriching device necessary in cold weather. Gasoline does not vaporize as readily at low temperatures, and in order to supply the cylinders with a gaseous mixture rich enough to be ignited, the proportion of liquid gasoline to air must be increased.

At the same time it is important not to apply the enriching device more than is necessary. The unvaporized gasoline collects on the cylinder walls and works down past the pistons, washing off the lubricant as it goes. Although dilution of the oil supply with this unburned gasoline is minimized in the La Salle engine by an exclusive system for ventilating the crankcase (see page 50), it is best to avoid an excess of liquid gasoline in the combustion chambers by careful and judicious use of the enriching device.

The following rule should govern the use of the enriching button in winter weather: Pull the enriching button back just as far as it is necessary to start the engine, but as soon as the engine starts, let the button return as far as possible without causing the engine to stop or slow down. Then release the button entirely as soon as the engine is warm enough to permit doing so.

In cold weather it is also a good plan to pull out the enriching button just before switching off the ignition to stop the engine. This will make it easier to start the engine.

Priming the Carburetor

In extremely cold weather, if the engine does not start after cranking for a few seconds with the enriching device fully applied, release the starter pedal. Then prime the carburetor by opening and closing the throttle once or twice rather rapidly with the accelerator. Opening

and closing the throttle operates a throttle pump on the carburetor and raises the level of gasoline in the carburetor bowl. The carburetor should never be primed in warm weather and should not be primed unnecessarily in cold weather. Excessive priming is likely to make starting difficult rather than easy.

Position of Throttle Hand Lever

The correct position of the throttle hand lever for starting in cold weather is the same as for starting under other conditions, that is, about one-fourth the way down from the idling position. In warm weather, however, the lever may be returned to the idling position almost as soon as the engine is started. In cold weather, the throttle must be left slightly open until the engine becomes warm.

Position of Spark Control Lever

It is the practice of some drivers to move the spark control lever all the way to "Retard", whenever starting the engine. This is the correct position if the engine is to be cranked by hand, but if the engine is to be cranked with the starter, there is no reason for retarding the spark, and in extremely cold weather "popping back" in the carburetor is less likely to occur if the spark is fully advanced.

Use of Starter

In extremely cold weather, when the car has been standing long enough to become thoroughly chilled, it is a good plan to disengage the clutch during the cranking operation. If this is not done, the starter is called upon to turn the jackshaft gears in the transmission in addition to cranking the engine. At ordinary temperatures, the additional energy required is negligible, but in extremely cold weather, the lubricant in the transmission offers sufficient resistance to rotation of the transmission gears to increase considerably the demand upon the battery and to retard the cranking speed.

Use of Accelerator Before Engine is Warm

In cold weather, after the engine has been started and before it has run long enough to become warm, the engine cannot deliver its normal power and it should not be called upon to do so. In accelerating the engine to start the car and in accelerating the car after the transmission is in gear, do not open the throttle suddenly or too far. To do so is not only to invite "popping back" in the carburetor, but to increase the amount of excess unvaporized gasoline in the combustion chambers, both of which results are undesirable. For this reason, also, starting in intermediate should never be attempted in cold weather.

PART II

LUBRICATION AND CARE



LA SALLE LUBRICATION SCHEDULE

CHAPTER I

Systematic Lubrication

OWNER'S NAME _____
 ADDRESS _____
 ENGINE NO. _____ DATE DELIVERED _____

Do not wait for schedule lubrications before adding engine oil. The oil level should be checked every 100 to 150 miles and oil added if the indicator ball is below "Full." This is especially important on cars driven at high speed.

LUBRICATION NO. AND MILEAGE AT WHICH DUE

LUBRICATION NO.	LUBRICANT	LUBRICATION NO. 1				LUBRICATION NO. 2				LUBRICATION NO. 3				LUBRICATION NO. 4			
		1000	2000	3000	4000	1000	2000	3000	4000	1000	2000	3000	4000	1000	2000	3000	4000
LUBRICATION NOS. 1 AND 3	CHECK RADIATOR LEVEL	WATER OR ANTI-FREEZE	○	○	○	○	○	○	○	○	○	○	○	○	○	○	○
	ADD ENGINE OIL AS NECESSARY	ENGINE OIL	○	○	○	○	○	○	○	○	○	○	○	○	○	○	○
	GENERATOR AND DISTRIBUTOR OIL CUPS	ENGINE OIL	○	○	○	○	○	○	○	○	○	○	○	○	○	○	○
	FAN—ADD ENGINE OIL	ENGINE OIL	○	○	○	○	○	○	○	○	○	○	○	○	○	○	○
	BRAKE PINS AND CONNECTIONS	ENGINE OIL	○	○	○	○	○	○	○	○	○	○	○	○	○	○	○
	SPRING LEAVES	ENGINE OIL	○	○	○	○	○	○	○	○	○	○	○	○	○	○	○
	DOOR HARDWARE	ENGINE OIL	○	○	○	○	○	○	○	○	○	○	○	○	○	○	○
	GREASE GUN CONNECTIONS (EXCEPT WATER PUMP)	CHASSIS LUBRICANT	○	○	○	○	○	○	○	○	○	○	○	○	○	○	○
	WATER PUMP	WHEEL BEARING GREASE	○	○	○	○	○	○	○	○	○	○	○	○	○	○	○
	*ADD WATER TO STORAGE BATTERY	DISTILLED WATER	○	○	○	○	○	○	○	○	○	○	○	○	○	○	○
LUBRICATION NO. 2	CHECK TIRE INFLATION		○	○	○	○	○	○	○	○	○	○	○	○	○	○	○
	**TEST OIL FILTER		○	○	○	○	○	○	○	○	○	○	○	○	○	○	○
	DRAIN AND REPLACE ENGINE OIL	ENGINE OIL		○	○	○	○	○	○	○	○	○	○	○	○	○	○
	CLUTCH THRUST BEARING	FIBER GREASE		○	○	○	○	○	○	○	○	○	○	○	○	○	○
	TRANSMISSION—ADD LUBRICANT	CHASSIS LUBRICANT		○	○	○	○	○	○	○	○	○	○	○	○	○	○
	REAR AXLE—ADD LUBRICANT	CHASSIS LUBRICANT		○	○	○	○	○	○	○	○	○	○	○	○	○	○
	STEERING GEAR—ADD LUBRICANT	CHASSIS LUBRICANT		○	○	○	○	○	○	○	○	○	○	○	○	○	○
	REAR WHEEL BEARINGS	CHASSIS LUBRICANT			○	○	○	○	○	○	○	○	○	○	○	○	○
	FRONT WHEEL BEARINGS	WHEEL BEARING GREASE			○	○	○	○	○	○	○	○	○	○	○	○	○
	SPEEDOMETER DRIVE SHAFT	WHEEL BEARING GREASE			○	○	○	○	○	○	○	○	○	○	○	○	○
LUBRICATION NO. 4	***FLUSH COOLING SYSTEM				○	○	○	○	○	○	○	○	○	○	○	○	
	****REFILL SHOCK ABSORBERS	SPECIAL OIL														○	

THE FOLLOWING OPERATIONS CANNOT BE PLACED ON A MILEAGE BASIS AND ARE NOT INCLUDED IN THE ABOVE SCHEDULE:

REMOVE OIL PAN AND CLEAN PAN AND SCREEN—ONCE A YEAR OR WHENEVER OIL FILTER IS CHANGED.

TURN REAR AXLE AND TRANSMISSION LUBRICANT AS REQUIRED FOR LOW TEMPERATURES.

DRAIN AND REPLACE REAR AXLE AND TRANSMISSION LUBRICANT—AT BEGINNING OF MILD WEATHER IN SPRING.

**IN SUMMER, INSPECT BATTERY EVERY 500 MILES OR AT LEAST EVERY 2 WEEKS.

***AFTER FIRST 15,000 MILES.

****NOT INCLUDED IN LUBRICATION NO. 4

****EVERY 12,000 MILES

RECORD ON OTHER SIDE

Necessity for Lubrication

The quiet, dependable operation of a new car is primarily the result of the accurate finishing of surfaces separated from each other by a few thousandths of an inch. In the La Salle, there are hundreds of such surfaces. If the clearances between these surfaces are to be maintained, so that the car will continue to operate quietly and dependably, wear must be prevented and the only way this can be done is by correct lubrication.

Cadillac engineers have provided for the lubrication of all surfaces where friction is a factor. The most that a manufacturer can do, however, is to provide a place for the lubricant and means for it to reach the surfaces to be lubricated. The car cannot be equipped with an inexhaustible supply of lubricant. Upon the car owner devolves the responsibility of replenishing the supply at the proper time with lubricant of the prescribed specifications.

Because of the importance to the car owner of proper lubrication of his car, every effort has been made in this Manual to give explicit information. Lubricant is prescribed for each point requiring lubrication, directions are given for applying it, and recommendations are made as to the frequency with which it should be applied.

Lubrication Schedule

Systematic lubrication, at regular mileage intervals, is the only kind that is effective. On page 44 is a complete lubrication schedule which, if faithfully followed, will insure correct lubrication for each wearing surface.

The unit of the La Salle lubrication schedule is 4000 miles, which is divided into four 1000-mile intervals. Corresponding to these is a series of four consecutive groups of lubricating operations. When the car has traveled 1000 miles the points enumerated under Lubrication No. 1 should receive attention. At 2000 miles, Lubrication No. 2 is due, and so on until at 4000 miles Lubrication No. 4 should be performed. At 5000 miles the schedule begins again with Lubrication No. 1.

In order that the driver may be continually reminded of the mileage at which the next lubrication is due, the speedometer is provided with

Figure 24. This is a fac-simile of the La Salle Lubrication Schedule and Record. Provision is made on the back of the card for recording when and where the car is lubricated. A copy of this card can be obtained on request from Cadillac distributors and dealers.

a lubrication notice. This consists of a strip of black celluloid (Fig. 25) which is placed across the speedometer cover glass below the total mileage dial and which has two white spaces, one for the lubrication number and one for the mileage at which it is due.



Figure 25. Lubrication notice.

Note: Do not wait for the mileage indicated on the notice before adding engine oil. The oil level should be checked every 100 to 150 miles and oil added, if the indicator ball is below "Full."

Whenever the car is lubricated on the schedule, the figures then on the celluloid should be erased and the next lubrication number and the mileage at which it is due should be written or stamped in their places. If this notice is used, the driver need only glance occasionally at the speedometer and compare the mileage on the dial with the figures on the notice in order to plan for the necessary attention.

Cadillac distributors and dealers are prepared to sell lubrication based on this schedule. A car that is being lubricated on the schedule can be taken to any authorized Cadillac service

station, and without further ordering than to specify "Schedule Lubrication," the car will receive the necessary attention.

Lubricants

The selection of proper lubricants for the La Salle car should be one of the first concerns of the owner in his attention to the lubrication of the car. The lubricants must not only be of high quality, but their viscosity and other characteristics must be suited to the car.

The owner is urged to consult the distributor or dealer from whom he purchased his car in regard to the names of lubricants which have been tested and approved for use in the La Salle car.

Engine Oil

It is particularly important that only approved engine oils be used for high-speed, continuous driving. Other oils cannot be depended upon to give satisfactory lubrication and economical mileage under such conditions. If, in an emergency, an unapproved oil must be used, special care must be taken to watch the oil level and add oil as soon as the level drops to "Fill."

During winter it may be necessary to thin the engine oil with kerosene in order to make the engine crank easily. See page 39 for instructions on lubrication in cold weather.

Chassis Lubricant

Lubricant conforming to the specifications for Chassis Lubricant is recommended for the transmission, rear axle, steering gear and all chassis points fitted with grease gun connections, except the water pump.

Lubricants conforming to these specifications may be used without thinning during all weather except winter weather below temperatures of 20° above zero. Below this temperature, thinning with kerosene is necessary in order to secure easier gear shifting, easier steering and proper lubrication of gears and bearings.

Wheel Bearing and Cup Grease

Greases approved under the specifications for Wheel Bearing and Cup Grease are suitable for lubricating the front wheel bearings and the water pump. This grease is not recommended for chassis lubrication, as Chassis Lubricant is much more effective.

Fiber Grease

Fiber grease approved under the specifications for this type of lubricant is recommended for the clutch thrust bearing.

CHAPTER II

Engine Lubrication

Oil Circulating System

The supply of oil is carried in the pressed steel reservoir that covers the bottom of the crankcase. The oil is circulated by a gear pump attached to the front main bearing cap inside of the crankcase. The pump is driven by a vertical shaft which is in turn driven by a spiral gear on the camshaft.

The pump draws oil from the bottom of the reservoir and delivers it under pressure to the bearings. Oil reaches the front main bearing through a passage in the bearing cap. A supply pipe from the pump runs the length of the engine parallel to the crankshaft and leads branch off from it to feed the center and rear main bearings. From the rear bearing the oil is conducted to the hollow camshaft through which it flows forward and lubricates the camshaft bearings.

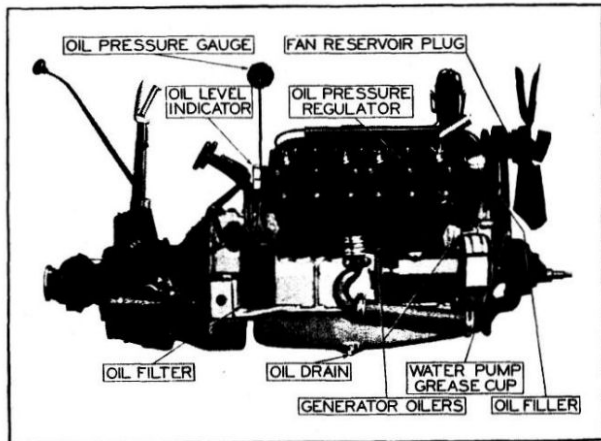

Figure 26. Showing the location of the oil filler, oil level indicator, oil pan drain plug and other lubrication features.

The oil is carried from the front end of the camshaft to the oil pressure regulator, which is attached to the crankcase just ahead of the right-hand cylinder block. The regulator contains a by-pass with metering screw for adjustment of the oil pressure at idling speeds and a spring-controlled valve that opens to prevent excessive pressure at high speeds. The oil that passes the regulator, either through the by-pass or around the valve, lubricates the front end chains.

The valve stems are automatically lubricated by oil sprayed from two small holes drilled in the wall of each cylinder at such a distance from the bottom of the cylinder that, when the piston is at the bottom of its stroke, these holes register with a groove in the piston between the second and third piston rings. As the piston descends on the power stroke, the oil collects in this groove and as soon as the groove registers with the holes, the pressure of the gases above the piston forces oil out upon the valve stems. Surplus oil collecting in the valve compartments is returned to the crankcase through drain passages.

All oil returns to the pan through a fine mesh screen in the oil pan.

Oil Level

The normal capacity of the oil pan is two gallons, which fills it to the level of the screen in the pan. When the oil pan contains this amount, the oil level indicator on the right-hand side of the engine (Fig. 26) indicates "Full." As the oil level descends, the indicator indicates "Fill" and then "MT" (Empty). Oil should be added as soon as the indicator ball has dropped to "Fill." If the indicator indicates "MT," under no circumstances should the engine be run until oil has been added.

The mileage interval at which oil must be added depends upon individual circumstances. *It is recommended that the oil level indicator be checked every one hundred to one hundred and fifty miles, although it is improbable that oil will be required as frequently as this.*

Oil Pressure

The pressure of the oil in the supply pipe is indicated by the oil pressure gauge on the instrument panel (Fig. 6).

It is absolutely necessary that there be oil pressure just as soon as the engine starts and as long as the engine is running. If the oil pressure gauge does not indicate pressure as soon as the engine starts, stop the engine at once and investigate the cause. First, check the level of oil in the oil pan. If the level is above "Fill," consult the nearest Cadillac service station.

The amount of pressure indicated by the gauge depends upon several things: the kind of oil, the temperature of the oil and the speed of the engine. With fresh oil of the correct viscosity, the oil pressure at idling speed should be from 7 to 10 lbs. after the engine has become thoroughly warm.

The pressure indicated at speeds above idling speed may be assumed to be correct if the pressure at idling speed is correct.

Crankcase Ventilating System

In every internal combustion engine, seepage of vapors by the pistons takes place to some extent, permitting water vapor and other products resulting from combustion, as well as unburned gasoline, to enter the crankcase. Contamination of the lubricating oil from this source makes it necessary in most engines to replace the oil supply at frequent intervals.

La Salle engines are equipped with a system to prevent the seepage vapors from entering the crankcase. To bring about this result, advantage is taken of the fact that the La Salle crankshaft with its compensating weights acts naturally to draw air through an inlet in the left-hand side of the engine, building up within the crankcase a pressure slightly above the atmospheric pressure. No outlet is provided in the crankcase itself, but in the wall of each cylinder is a port connecting the space below the piston with the valve compartment. The port is open except when the piston is at the extreme bottom of its stroke.

The effect of this arrangement is as follows: The seepage vapors that pass the two upper piston rings are forced through slots milled in the circumference of the lower piston ring and through corresponding holes in the piston into the space inside the piston, where they are carried down as the piston descends. The vapors cannot enter the crankcase, however, because they are prevented from doing so by the pressure built up in the crankcase by the revolving crankshaft. Instead, the vapors are expelled through the port into the valve compartment. From the valve compartments, the expelled vapors are conducted through pipes underneath the car where they are discharged.

Oil Filter; 16*

Another source of contamination of the oil supply is dirt. In the La Salle engine all solid matter in the oil is removed by means of a

*The numbers following the headings in this chapter and Chapter III refer to Fig. 28.

filter, which is attached to the right-hand side of the engine and which is connected to the oil circulating system.

The filter is connected to the oil line by a pipe that leads from a tee on the crankcase at the rear of the right-hand cylinder block. The oil pressure gauge on the instrument board is also connected to this tee. Oil is thus forced to the filter whenever the engine is running and there is pressure in the oil line.

When the filter cartridge is new, the capacity of the filter is such that at a car speed of 25 to 30 miles per hour, the quantity of oil in the crankcase will pass through the filter approximately every five minutes. This rate of flow will gradually decrease until the filter ceases to function due to clogging, and when this occurs it will be necessary to replace the filter cartridge. The filter is provided with a safety valve which prevents excessive pressure on the filter tank.

To determine whether oil is passing through the filter, open the T-shaped valve on the filter fitting. If oil flows from the opening, the filter is operating. When performing this test the engine must be running and should be sufficiently warm to allow free oil flow. Make sure that the valve is tightly closed after the test is completed.

It is important that the filter cartridge be replaced just as soon as the filter ceases to function. Otherwise the whole purpose of the filter is defeated and wear of the engine parts will result from the dirty oil.

Under average conditions, replacement of the filter cartridge is recommended every 10,000 miles. In any event the flow of oil through the filter should be tested at the end of 10,000 miles and every 1000 miles thereafter until the filter cartridge is replaced. Filter cartridges for replacement can be obtained from Cadillac distributors and dealers or from United Motors Service stations.

Replacing Engine Oil; 14

Although the crankcase ventilating system and the oil filter described in the preceding sections greatly prolong the useful life of the oil, it is recommended that the oil be drained and replaced with fresh oil every 2000 miles.

To drain the oil, simply remove the drain plug (Fig. 26). Be sure to reinstall the drain plug before adding the fresh oil. Two gallons of fresh oil should be added, or enough to bring the oil level indicator ball to "Full."

At the end of the first 1000 miles, it is recommended that the car be taken to a Cadillac service station to have the oil pan and screen

removed and cleaned with gasoline or kerosene. This should be repeated once a year or whenever the filter unit is replaced.

Generator Oil Cups; 15

Two oil cups on the generator conduct lubricant to the forward and rear bearings on the armature shaft. A few drops of engine oil should be applied to each cup every 1000 miles.

Timer-Distributor Oil Cup; 10

The oil cup at "10" is for lubricating the ball bearing at the upper end of the timer-distributor shaft. A few drops of engine oil should be applied every 1000 miles.

Fan; 9

The fan is lubricated by oil contained in a reservoir in the fan hub. The screw plug in the outside of the reservoir should be removed every 1000 miles and engine oil should be added to bring the oil to the proper level. In adding oil, it is necessary to add somewhat more than enough and then drain off the surplus by turning the fan so that the hole points down. A short stand-pipe inside the reservoir insures that the proper amount of oil is retained. If no oil runs from the hole when it is first turned down, do not assume that the oil level is correct. Sometimes the reservoir is "air-bound," and the hole should be left pointing down for at least half a minute to give the air a chance to work in. A cloth or piece of waste may be held under the hole to catch the oil.

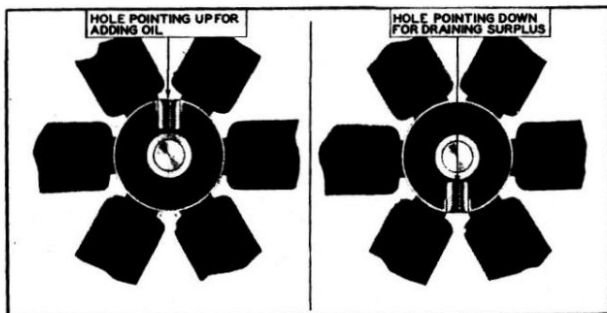

Figure 27. Oil for lubricating the fan is carried in the fan hub. The supply should be replenished every 1000 miles. Grease or heavy oil must never be used in the fan.

Do not put heavy oil or grease in the fan.

Water Pump; 13

A grease cup is provided for lubricating the water pump. This cup should be turned down and refilled with cup grease every 1000 miles.

Front Engine Support; 7

A grease gun connection is provided for lubricating the front engine support. Chassis lubricant should be applied with the grease gun every 1000 miles.

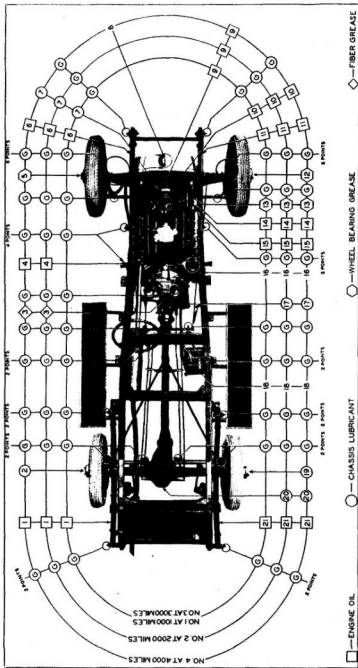

Figure 28. Each "G" represents a grease gun connection. Each number indicates a lubricating point for which instructions are given in Chapters II and III.

CHAPTER III

General Lubrication

Grease Gun Connections; G

Spring bolts, steering connections, brake rocker shafts and other points are provided with connections to fit the grease gun supplied with the tool equipment. These points are indicated by "G" in Fig. 28. Chassis lubricant as specified on page 47 should be applied to these points with the grease gun every 1000 miles.

Clutch Thrust Bearing; 3

The lubricating point on the clutch thrust bearing is fitted with a grease cup on an extension that passes through the right-hand side of the transmission case. It can be reached after lifting the right side of the hood.

The grease cup should be filled with fiber grease and turned down two or three times every 2000 miles.

Transmission; 17

The transmission case should contain sufficient lubricant to bring the level up to the filling hole at the right-hand side. The level should be inspected every 2000 miles and chassis lubricant added if necessary.

If, in cold weather, the transmission gears are difficult to shift, the lubricant should be thinned by the addition of kerosene. On the return of warm weather in the spring, the drain plug should be removed from the bottom of the transmission case and the lubricant should be drained and replaced with fresh lubricant. One and one-half quarts of lubricant are required to fill the transmission case to the proper level.

Rear Axle; 20

The rear axle housing should contain enough lubricant to bring the level up to the filling hole in the rear cover plate. The level should be inspected every 2000 miles and chassis lubricant added if necessary.

In weather cold enough to warrant thinning the transmission lubricant, the lubricant in the rear axle should also be thinned. On the return of warm weather in the spring the drain plug should be removed from the bottom of the axle housing and the lubricant should be

drained and replaced with fresh lubricant. Three quarts of lubricant are necessary to fill the rear axle housing to the proper level.

Front Wheels; 5, 12

The wheel bearings are packed in grease when the car is assembled. Every 4000 miles the front wheels should be removed and the bearings should be thoroughly cleaned in gasoline or kerosene. They should then be repacked with wheel bearing and cup grease and the bearings adjusted in accordance with the directions on page 107.

Rear Wheels; 2, 19

Every 4000 miles the screw plugs in the rear wheel hubs should be removed and chassis lubricant should be injected with the grease gun. On cars with wire wheels, the wheels must be removed to reach the plugs in the hubs. On cars with disc wheels it is necessary to remove the hub caps and the dust caps underneath them in order to reach the plugs in the hubs.

Steering Gear; 4

The grease gun connection for adding lubricant to the steering gear is on top of the housing just at the base of the steering column. Chassis lubricant should be added every 2000 miles. If, in cold weather, the car steers hard, the lubricant should be thinned by the addition of kerosene.

Speedometer Flexible Drive Shaft

The flexible shaft by which the speedometer is driven is housed in a flexible casing. To lubricate the speedometer drive shaft, the shaft should be removed from its casing and lubricant applied to it for its entire length. Cup grease is recommended for this lubrication, which should be performed every 4000 miles.

Do not under any circumstances attempt to lubricate the speedometer itself. Any parts in the speedometer requiring lubrication are amply supplied when it is assembled.

Springs; 1, 6, 11, 21

To lubricate the spring leaves, it is recommended that the edges and ends of the leaves be painted with engine oil every 1000 miles. A small stiff brush should be used. After applying the oil, the car should not be washed until it has been driven far enough to allow the lubricant to work in between the leaves. Do not separate the leaves and insert

lubricant. A certain amount of friction between the spring leaves is necessary in order to give the springs the desired characteristics.

If spring covers are used, it is not necessary to lubricate the spring leaves as directed in the preceding paragraph. It is sufficient to repack the springs once a season with petroleum jelly.

Door Hardware

Whenever the chassis is being lubricated, the door locks and other door hardware should also be lubricated as follows:

Place a few drops of oil on each door lock plunger or striker, turning the handle back and forth so that the oil will work into the lock. Also place a drop of oil on each of the striker plates against which the strikers engage when the doors are closed. The hinge pins should also be oiled sparingly so as not to get oil on the finish.

Each door has a wedge-shaped tongue that dovetails into a receptacle on the body when the door is closed. These tongues should receive a small amount of grease or oil.

Each closed car door is also fitted with a check at the top which limits the outward movement of the door. A small amount of grease should be applied to the pin that slides in the slot at the top of the door.

Cooling System; 8

The level of the liquid in the cooling system should be checked every 1000 miles. Every 4000 miles the system should be drained and flushed as directed on page 81.

Storage Battery; 18

Distilled water should be added to the cells of the storage battery at least every 1000 miles. (See page 85)

Shock Absorbers.

The Delco-Remy-Lovejoy shock absorbers with which La Salle cars are equipped should have oil added every 12,000 miles. If the oil in the shock absorbers is not up to the proper level, the normal spring action will not be obtained. The shock absorbers require a special oil which can be obtained from Cadillac distributors or dealers or United Motors Service Branches and authorized distributors.

CHAPTER IV

Care of Body

Care of Finish When New

ON CARS finished with varnish, more careful and more frequent attention is necessary when the car is new than after the varnish has hardened. Particular care should be taken to keep mud from the body and hood for the first few weeks. Even after the varnish has hardened, mud must not be permitted to remain on the finish over night or long enough to dry. If it is not possible to wash the car thoroughly before putting it away for the night, flush it off and then thoroughly wash the car the next morning. Mud permitted to remain on the car until it has dried is not only difficult to remove, but stains and dulls the finish.

The same degree of caution, although commendable, is not as necessary on cars finished with Duco, because Duco hardens much more quickly than paint or varnish.

Washing Varnished Cars

Use clean water and plenty of it. Do not use water containing alkali. In parts of the country where the regular water supply contains alkali, use rain water.

Do not use hot water as it destroys the luster. The temperature of the water should be between 40 and 60 degrees Fahrenheit. Do not wash the hood while it is hot, because the effect on the finish is the same as washing it with hot water. Unless the hood is allowed to cool before washing, the luster will soon disappear.

If a hose is used in washing, do not have pressure greater than will carry the water six inches beyond the end of the hose. Water under higher pressure drives the grit and dirt into the varnish. It is best not to use a nozzle.

Wash the chassis first, going over the under sides of the fenders, the wheels, and the running gear with water flowing gently from the hose. This will flush off most of the mud and dirt.

If it is necessary to use soap to remove road oil from the under side of the fenders, or machine oil or grease from the chassis, use a good automobile soap dissolved in a pail of water and apply the soapy solution with a sponge. Do not let this soapy solution remain on the finish

more than two or three minutes, but immediately wash it off thoroughly with a soft carriage sponge.

After washing the chassis, begin at the front of the car and flow water from the hose upon the body, hood and upper surfaces of the fenders. This will soften the accumulation of road dirt, removing most of it. Then go over the car again and remove all dirt by rubbing with a soft wool sponge, at the same time applying an abundance of water from the hose. The sponge, which should be kept exclusively for the body, hood, and upper surfaces of the fenders, should be rinsed frequently in clean water to remove any grit.

After the washing is completed, squeeze the sponge as dry as possible and pick up all water from crevices. Then thoroughly wet a clean, soft chamois, wring it as dry as possible, and dry the finish. Be sure and use a chamois that has not been used on the chassis. Rinse the chamois and wring it out frequently. Do not rub the finish or apply more pressure than is necessary to dry off the surplus water. The remaining water will evaporate quickly, leaving the finish in good condition.

If it is desired to chamois the wheels and chassis, and they have become dry, wet these parts with clean water and then wipe them. Be sure to use a separate chamois for the chassis. The chamois that has been used on the body should be saved for the body exclusively.

Do not use soap, gasoline, kerosene, or anything of similar nature on the finish. Such materials attack the finish.

Washing Duco

Although it is not necessary in washing cars finished in Duco to use the same degree of care as in washing varnished cars, nevertheless the same general directions should be followed.

Cleaning Windows

Do not clean the window glass with preparations that may contain harmful ingredients. Use only cleaning compounds that are known to have no destructive effects on highly polished glass.

Cleaning Upholstery

To keep the upholstery in closed cars in the best condition, it should be cleaned thoroughly at least once a month with a whisk broom and

vacuum cleaner. Dirt and grit accumulating in the fabric wear it out faster than use.

Spots on the upholstery may be cleaned with any good dry cleaner. When the cleaner has thoroughly evaporated, apply a hot flatiron wrapped in a wet cloth. Steaming the fabric and rubbing lightly against the nap will raise the nap to its normal position.

CHAPTER V

Care of Tires

EACH tire maker publishes a booklet with instructions for care and repair of tires. Every motorist should provide himself with one of these and thoroughly familiarize himself with the contents. The suggestions here apply to pneumatic tires in general.

Three-fourths of so-called "tire trouble" is the result of misuse. We give here some suggestions regarding the more important points of the care of tires.

Result of Under-Inflation

Under-inflation causes a tire to flatten out under load. This causes the side walls to bend sharply as the tire revolves. The result is the breaking of the side walls. An under-inflated tire is susceptible to bruise, broken cords and blow-out.

Result of Improperly Aligned Front Wheels

Running a car with the front wheels out of alignment causes rapid tread wear. This usually affects both tires similarly, although sometimes only one tire is affected. An incorrect adjustment of the front axle parallel rod or a bent steering arm is responsible for the condition. Unless the wheels are in proper alignment the treads of the front tires will wear away in a remarkably short time.

Neglect of Small Cuts

If cuts extending to the cords are neglected, deterioration and blistering of the tire tread is the result. It is unnecessary to remove a tire to treat small cuts of this nature. Tire companies furnish a plastic compound for filling cuts. This prevents moisture and dirt from getting in. If a cut is large, it should be vulcanized at once.

Result of Improperly Adjusted Tire Chains

Tires are sometimes badly damaged through the use of tire chains which are incorrectly adjusted or which are fastened to the spokes of the wheel holding the chains tightly in place.

The least injury results when chains are applied loosely, leaving play enough to permit them to work around. The wear on the tire is thus

distributed evenly. Probably the greatest amount of injury comes from using chains unnecessarily on paved streets.

Result of Sudden Application of the Brakes

The sudden application of the brakes resulting in sliding the wheels causes the tread to wear away in spots. A tire will give away very rapidly under this severe treatment.

Additional Suggestions

The tires are constructed for the purpose of carrying up to certain maximum loads and no more. It should be realized that overloading a car beyond the intended carrying capacity is sure to materially shorten the life of the tires. Do not turn corners or run over sharp obstructions, like car tracks, at a high rate of speed. Such practice is sure to strain or possibly break the cords, with the result that the further life of the tires will be limited. Remember that most tire troubles are the result of abuse.

Avoid scraping the tires against the curb and running in ruts. This kind of wear scrapes off the rubber wall and exposes the layers of cords to dirt and moisture, which soon starts to rot the cords.

In turning in a narrow street, avoid striking the curb.

If a tire goes flat without any indication of injury to the tire, see that the valve is not leaking. A little moisture on the tip will show bubbles if the air is escaping.

In case of puncture, the car should be stopped at once and the tube repaired or replaced, or the tire replaced by the extra one. The tire should also be examined carefully and the cause of the puncture ascertained and the nail, glass or whatever it may be, should be extracted. Before replacing the tire on the rim, examine the inside of the casing, to see that the cause of the puncture is not still protruding. It is also advisable to look over the outside of the tires frequently and take out any pieces of glass or other particles which may have become imbedded in the casing.

Don't run in ruts or car tracks; the sides of a tire will soon wear out under such treatment. Avoid large stones or other obstructions in the road. To hit one of these may break the carcass even though no external injury be visible.

The garage floor should be kept free from oil or gasoline. The tires on a car left standing on a grease-covered floor deteriorate quickly, the

natural enemies of rubber being oil and gasoline. These destroy the nature of the rubber, rendering it soft, so that it cuts and wears away quickly.

If the car is not used during the winter, it is better to remove the tires from the rims, keeping casings and tubes in a fairly warm atmosphere away from the light. It will be better to slightly inflate the tubes as that keeps them very nearly in the position in which they will be used later on. If the tires are not removed and the car is stored in a light place, it will be well to cover the tires to protect them from the strong light, which has a deteriorating effect on rubber.

CHAPTER VI

Storing Car

If **THE** car is not to be used for a period of several months, it should be protected from deterioration during the period when it is not in use by carefully preparing it for storage.

Engine

To prepare the engine for storage, proceed as follows: Run the engine until opening of the radiator shutters indicates that the engine is warm. This may be done by driving on the road or by running the engine idle. In the latter case care should be taken that there is sufficient ventilation to avoid injury from carbon monoxide poisoning. (See page 21.)

After the engine is warm, place the car where it is to be stored and shut off the flow of gasoline to the carburetor by turning the valve above the filter. As soon as the engine starts to slow down raise the polished aluminum cap on top of the carburetor and inject three or four tablespoons of clean fresh engine oil into the carburetor. Injection of the oil will stop the engine.

Remove the spark plugs. Inject two or three tablespoons of engine oil into each spark plug hole and before replacing the plugs crank the engine three or four revolutions with the ignition switched off. This will tend to distribute the oil over the cylinder walls. The engine should not be started again after injecting the oil. If it is started, it will be necessary to repeat the treatment.

Storage Battery

If the car is to be stored during the winter, the storage battery should have special treatment in order to protect it against freezing.

Shortly before the car is used for the last time, distilled water should be added to bring the level of the solution up to the bottom of the filling tubes. (See page 86.) After the water added has had an opportunity to mix thoroughly with the acid solution by running the car or engine, the specific gravity should be taken with a hydrometer. If the specific gravity of the solution is above 1.270 there will be no danger of the acid solution freezing. If, however, the specific gravity is below 1.270, the battery should be removed and charged. *Unless the battery is fully charged or nearly so it is probable that the acid solution in the battery will freeze and cause extensive damage.*

(64)

The battery ground connection should in all cases be disconnected during storage as a slight leak in the wiring will discharge the battery and lower the specific gravity to the point where the solution may freeze.

If possible, the storage battery should be removed and charged from an outside source every two months during the storage period.

Tires

During storage of the car, it is best to remove the tires *from the rims* and to keep the casings and tubes in a fairly warm atmosphere away from the light. The tubes should be inflated slightly after the tires have been removed.

If it is not convenient to remove the tires from the car and the car is stored in a light place, cover the tires to protect them from strong light, which has a deteriorating effect on rubber.

The weight of the car should not be allowed to rest on the tires during the storage period. If tires are not removed, the car should be blocked up so that no weight is borne by the tires. The tires should also be partly deflated.

Body and Top

A cover should be placed over the entire car to protect it from dust. In storing an open car, the top should be up.

Taking Car Out of Storage

In putting into use again a car that has been stored, it is advisable, unless the storage battery has been removed and charged at periodic intervals, to remove the battery from the car and give it a fifty-hour charge at a four-ampere rate. If the battery has received periodic charges, or if the specific gravity is above 1.200, simply add distilled water to the proper level and connect the leads. If there is a greenish deposit on the terminals of the battery, remove this with a solution of bicarbonate of soda (common cooking soda) and water. Do not allow any of this solution to get into the battery.

Before starting the engine, drain the oil from the oil pan and remove and clean the oil pan and screen. After reinstalling the oil pan, add eight quarts of fresh engine oil. Fill the cooling system, being sure to use anti-freezing solution in freezing weather. Remove the spark plugs

and inject two or three tablespoonfuls of engine oil into each cylinder. Reinstall the spark plugs and, with the ignition switched off, crank the engine a few seconds with the starter to distribute the oil over the cylinder walls.

Start the engine in the usual manner. As soon as the engine starts, immediately let the carburetor enriching button go as far forward as possible without causing the engine to stop or slow down materially and then open the throttle until the ammeter reads approximately 10 with all lights switched off. While the engine is running lift the aluminum cap on top of the carburetor and inject from two to three tablespoonfuls of engine oil into the carburetor. It is a good plan to run the car outdoors as soon as this has been done. Release the carburetor enriching button entirely as soon as the engine is warm enough to permit it.

PART III

GENERAL INFORMATION

It is not the object of this section of the Manual to give complete directions for the repair and adjustment of La Salle cars. Most La Salle owners prefer to depend for the majority of such work on Cadillac Service Stations, where proper equipment and skilled workmen are available.

The details given here include general information regarding the construction of the car and some of the simpler adjustments and operations which do not require special equipment, and which, in emergency, can be performed satisfactorily by the average automobile mechanic.

CHAPTER I

Engine

Important Features of Construction

The La Salle engine is of the water-cooled, four cycle type with two L-head cylinder blocks of four cylinders each, placed at an angle of 90° between the blocks. The cylinders of one block are directly opposite those of the other block, the lower ends of opposite connecting rods working side-by-side on the same throw of the crankshaft.

The crankshaft has four throws or cranks, and three main bearings. The camshaft has four bearings and is driven by the crankshaft through a silent chain. The camshaft has sixteen cams, each operating one valve through a camslide which carries a roller.

The engine base is the aluminum crankcase that supports the cylinder blocks and carries the crankshaft and camshaft bearings. The crankcase is supported at the rear end by two arms which are cast integrally with the crankcase, and which are bolted to brackets on the frame. The front end of the engine is supported on a cross-member of the frame below the radiator.

Firing Order

In valve and ignition adjustments, the cylinders are referred to by numbers, the numbers indicating the order in which the cylinders fire. These numbers, the arrangement of which is shown in Fig. 29, are stamped on the cylinder heads near the spark plugs.

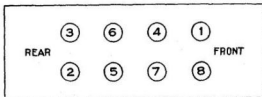

Figure 29. The cylinders fire in the order of the numbers shown here.

Main and Connecting Rod Bearings

The large diameter of the main and connecting rod bearings and the freedom of the crankshaft from vibration renders it ordinarily unnecessary to adjust these bearings for many thousands of miles. When bearing work is necessary, it should be performed only by one who is familiar with the work and who has the proper equipment.

(68)

The connecting rod bearings are cast in the connecting rods by a special process. When new connecting rod bearings are necessary, the entire rod should be replaced. Rods with new bearings can be procured from Cadillac distributors and dealers on an exchange basis.

Cylinder Heads and Removal of Carbon

La Salle cylinder heads are detachable, to facilitate access to the cylinders and combustion chambers for the removal of carbon.

To remove the cylinder head, first drain the water from the cooling system. Then disconnect the hose connections from the head by removing the two nuts that hold each outlet elbow to the head.

Remove the spark plugs. Remove the remaining nineteen nuts by which the cylinder head is held to the cylinder block. This will permit removal of the brackets holding the high tension ignition conduits.

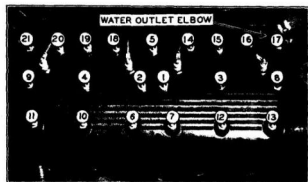

Figure 30. When installing the cylinder heads, tighten the nuts in the order shown above.

After removing the distributor head, the distributor head with ignition conduits can be removed out of the way. The cylinder head can be removed by lifting it off.

Carbon should be removed only with a soft iron scraper or wire brush. When re-installing the cylinder head, tighten the cylinder head nuts in the order shown in Fig. 30. After all nuts are tightened lightly, go over them again, tightening them firmly.

Adjustment of Valve Stem Clearance

It is important that the clearance between the lower end of each valve stem and the head of the adjusting screw in the camslide be

properly adjusted. If this clearance is too small, the valve will not close properly and over-heating and pitting of the valve and its seat are likely to result.

In order to adjust this clearance, it is necessary for the cam to be in the correct position, which is when the piston in the corresponding cylinder is on firing center.

With the piston thus on firing center, the valve stem clearance for the inlet valve should be .004 inch and for an exhaust valve .006 inch, when the engine is cold.

To adjust a camslide, loosen the locking screw with a suitable screw-driver and turn the adjusting screw with a wrench (Fig. 31). After the correct clearance has

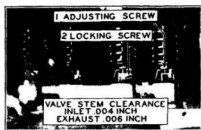

Figure 31. The valve stem clearance must be accurately adjusted.

been obtained, tighten the locking screw.

When installing the valve compartment cover plates be sure the ribbed surface is toward the outside.

Grinding Valves

Valve grinding will seldom be necessary if the valve stem clearance has been correctly adjusted. Valves should not be ground unless they require it. Misfiring is often due to incorrectly adjusted timer contact points or other causes besides leaking valves. A competent tester can determine quickly whether the misfiring is due to ignition or valves.

No attempt can be made here to describe in detail the procedure for grinding valves. The following are in the nature of suggestions and cautions to one who is already familiar with the general method of valve grinding.

If the seats on the valves are grooved or pitted, they should be refaced in a suitable grinder. If the seats in the cylinder blocks are very rough, they should be cleaned up with a reseating tool.

The angle of the inlet valve seats is 30° , and the angle of the exhaust valve seats is 45° . When refacing valves, be sure to set the machine to these angles, and when reaming valve seats use reamers with the proper angles.

Be very careful to leave none of the grinding compound in any part of the cylinder, as it will cause serious damage if it works into the cylinder bore or other parts of the engine.



Figure 32. Sectional view through sprocket for water pump and generator drive.

After grinding the valves, be sure to readjust the valve stem clearance, as described in the preceding section.



Figure 33. The water pump and generator driving chain should not be adjusted too tight.

Chains

The chain which drives the water pump and generator is adjustable to take up any slack that may develop. Adjustment should be made after the first 2000 miles of travel, after that adjustment will not be required oftener than every 10,000 miles.

To make the adjustment, it is necessary to remove the right-hand mud pan, but it is not necessary to remove the generator or water pump.

After removing the mud pan and the oil filler, loosen the nuts on the two bolts which pass through the upper part of the housing to which the water pump and generator are fastened. Loosen also the two screws, one on each side of this housing at the bottom (Fig. 32). Loosen the two screws by which the water pump is fastened to the sprocket support. This permits the hose between the pump and the radiator to align itself as the sprocket support is moved.

With a bar or lever pry against the support to which the water pump is attached, forcing it out from the engine as far as it will go. Holding the lever in this position, mark the support and the housing. Then release the lever, allowing the support to move back toward the engine $\frac{1}{8}$ inch. Hold the support at this point and tighten the two bottom screws and the nuts on the two upper bolts. Also tighten the water pump screws.

The camshaft driving chain requires no adjustment.

CHAPTER II

Gasoline System

General Description

The general arrangement of the gasoline system is illustrated in Fig. 34. The supply of fuel is carried in a 20-gallon tank at the rear, from which it is fed by vacuum to a tank on the dash. The fuel flows from this tank to the carburetor by gravity.

The vacuum for feeding the fuel from the supply tank to the tank on the dash is supplied from two sources: (1) The intake header and (2) a special vacuum pump driven by an eccentric on the rear end of the camshaft. The vacuum of the intake header alone is insufficient at wide open throttle to insure adequate flow of fuel and the pump is provided to supplement the intake header and furnish an adequate vacuum at all times.

The vacuum tank (Fig. 35) consists of an outer chamber and an inner chamber, the bottom of which communicates with the outer chamber through a flapper valve. The feed pipe from the supply tank enters the inner chamber of the vacuum tank which contains a float. This float

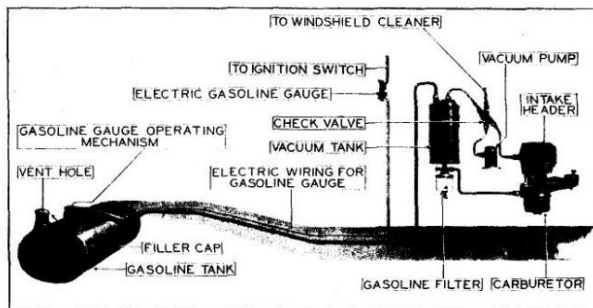

Figure 34. The gasoline is fed by vacuum from the supply tank to the vacuum tank on the dash and from there to the carburetor by gravity.

operates two valves, one in the passage to which the intake header and suction pump are connected, and the other in a passage communicating with a vent tube open to the atmosphere. When the float is

down, the vent valve is closed and the vacuum valve is open. When the float is up, the vacuum valve closes and the vent valve opens.

Operation of Vacuum Tank

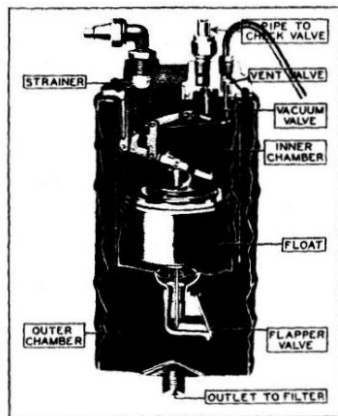

Figure 35. Sectional view of vacuum tank. There is a check valve in the connection to the intake header which prevents back-flow when the vacuum of the header is less than that of the pump.

weight of gasoline, emptying the contents of the inner chamber into the outer chamber. The float drops simultaneously, and, as it reaches the bottom, again operates the valves, this time opening the vacuum valve and closing the vent valve. The cycle thereupon starts again.

This alternate filling and emptying of the inner tank is repeated rapidly until the level of gasoline is the same in the inner and outer chambers, and therefore only as the carburetor demands fuel.

Ordinarily, there is enough fuel in the carburetor and in the vacuum tank to start the engine. If not, the automatic feeding action can usually be started by closing the throttle and operating the starter for about ten seconds. Wait a few seconds to allow the fuel to flow to the carburetor, and then start the engine as usual.

The action of the system in operation is as follows:

Starting with the inner chamber empty and the float at the bottom, the vacuum valve is open and the vent valve is closed. The suction of the intake header and the vacuum pump immediately causes gasoline to be drawn through the feed pipe to the inner chamber. The flapper valve is held closed by the vacuum within the inner chamber and the level of gasoline in the inner chamber rises until the float reaches the top of its travel, closing the vacuum valve and opening the vent valve. This breaks the vacuum in the inner chamber and the flapper valve at the bottom opens under the

The flow of fuel from the supply tank depends upon the difference in pressure between the vacuum tank and the supply tank. It is, therefore, essential that the supply tank be open to atmospheric pressure. For this reason, the vent hole in the gasoline filler cap *must* be kept open.

Gasoline Filter

A gasoline filter (Fig. 36) is provided in the gasoline line between the vacuum tank and the carburetor. This filter has a glass bowl through which the accumulation of water and sediment can be easily seen. The bowl should be removed and the gauze screen should be cleaned, as soon as any accumulation appears in the bowl. This can be done as follows:

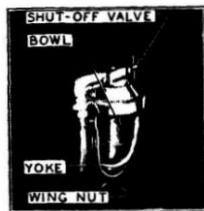

Figure 36. To remove the filter bowl for cleaning the screen, close the shut-off valve, loosen the wing nut at the bottom and disengage the supporting yoke.

First shut off the gasoline by turning clockwise the small T-handle valve at the side of the filter. Then unscrew the thumb screw under the bowl, after which the yoke supporting the bowl can be swung to one side and the bowl can be removed. If the screen does not come off with the bowl, it can be removed by pulling it straight down.

In putting back the bowl, make sure that it seats properly against the cork gasket in the top of the filter before tightening the thumb screw. Do not forget to turn the gasoline on by turning the valve counter-clockwise as far as it will go.

There is also a strainer in the vacuum tank at the point where the gasoline enters the inner chamber. The strainer should be removed and cleaned occasionally. The strainer is accessible after disconnecting the feed pipe and unscrewing the inlet elbow. To unscrew the elbow it is also necessary to remove the check valve (Fig. 35).

Adjustment of Carburetor

The carburetor should not be tampered with unless it needs adjustment. Good carburetor action cannot be expected before the engine is thoroughly warmed up. This is particularly true during cold weather. Imperfect carburetor action while the engine is cold does not indicate



Figure 37. Before adjusting the carburetor, make sure that the enriching control rod is properly adjusted.

the instrument board is forward as far as it goes (Fig. 37). If the tongue does not stand in the center of the slot, readjustment should be made by altering the length of the control rod.

The next adjustment to be checked is that of the throttle stop screw for controlling the idling speed of the engine (Fig. 38). Under normal conditions, this speed should be about 300 R.P.M. To adjust the idling speed, loosen the set screw in the collar on the control rod running from the steering gear to the lever on the accelerator pedal shaft on the front face of the dash. Then adjust the stop screw on the carburetor until the correct idling speed is obtained. When the throttle stop screw at the carburetor has been correctly adjusted, then move the throttle control lever to the closed position and set the collar on the control rod $\frac{1}{2}$ inch from the trunion on the lever.

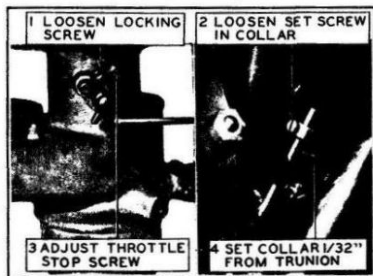

Figure 38. The idling speed, which should be about 300 r.p.m., is controlled by the throttle stop screw.

that the carburetor requires adjustment, and carburetor adjustment should not be made under such conditions.

If possible, the carburetor should be adjusted by an authorized Cadillac service station. The following instructions, however, are given for reference when a Cadillac service station is not convenient.

In adjusting the carburetor, select a quiet place, for correct adjustment depends largely upon being able to detect slight changes in engine speed.

Before making any other adjustments, make sure that the tongue on the auxiliary air valve shaft stands in the center of the slot in the enriching control lever, when the button on the instrument board is forward as far as it goes (Fig. 37). If the tongue does not stand in the center of the slot, readjustment should

If the mixture is so far from correct that the engine will not idle as slowly as 300 R.P.M., close the throttle as far as possible without stalling the engine, and proceed with the adjustment of the auxiliary air valve.

The auxiliary air valve spring, which constitutes the main adjustment of the carburetor, is adjusted by the knurled adjusting screw shown in Fig. 39. Before turning this screw to make any adjustment, determine whether the mixture is lean or rich. Start the engine and run it until the engine is thoroughly warm. Place the spark lever in the fully retarded position and move the throttle lever to the closed position.

Then press down gently on the ball-shaped counterweight of the auxiliary air valve, and note whether the immediate result is an increase or a decrease in engine speed. Release the counterweight and

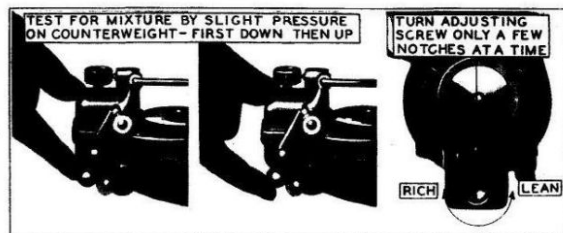

Figure 39. The principal carburetor adjustment is the auxiliary air valve. This should be done with the spark retarded and the hand throttle in the idling position.

allow the engine to run a few seconds to regain its normal speed. Then press gently up on the counterweight and note the effect on the engine speed.

If the mixture is correct, the immediate result of gentle pressure, either up or down, on the counterweight of the auxiliary air valve will be a slight decrease in engine speed. If the immediate result of gentle upward pressure is a slight decrease in engine speed, while the result of downward pressure is an increase in engine speed, a rich mixture is indicated. If the immediate result of upward pressure is an increase in engine speed, a lean mixture is indicated.

If this test indicates an incorrect mixture, adjust the auxiliary air valve screw by turning it clockwise to correct a lean mixture and

counter-clockwise to correct a rich mixture. Continue to change the adjustment of this screw and to test as above until a correct mixture is indicated. Do not turn the screw more than a few notches at a time, and not more than two notches at a time when nearing the correct adjustment.

If, after adjusting the auxiliary air valve, the engine idles too fast, readjust the throttle stop screw.

Gasoline Tank Gauge

As explained on page 9, the gasoline gauge is an electrical device and is connected in the ignition circuit. It is therefore in operation only when the ignition is switched on. The purpose of this arrangement is so that the gauge will not draw current while the car is not in use.

When the ignition is switched off, the gauge hand may come to rest anywhere on the gauge. It does not return to zero, nor does it ordinarily stay in the position it had before the ignition was switched off. At such times, therefore, the reading of the gauge is not a true reading. A true reading is given only when the ignition is switched on.

It is of vital importance that the electrical connections in the gauge circuit be correctly made. If the connections are reversed, the gauge will not only fail to register correctly, but is likely to be injured.

CHAPTER III

Cooling System

Water Circulation

THE La Salle engine is cooled with water circulated through the jackets of the cylinder blocks by a centrifugal pump. This pump is mounted on the right-hand side of the engine near the front, and is driven by a chain from the crankshaft. The pump draws cold water from the bottom of the radiator and delivers it to a connection on the right-hand side of the engine, where the stream divides, half going to the right-hand cylinder block and half through a passage in the crankcase to the left-hand cylinder block. From the front end of each cylinder head, an outlet pipe with hose connections carries the heated water to the top of the radiator.

Adjustment of Fan Belt

The tension of the fan belt must be maintained correctly. If the belt is too loose the fan will slip, and if it is too tight, an unnecessary load will be imposed on the bearings.

To test the tension of the fan belt, slip the fan by pulling on one of the blades. If it is difficult or impossible to slip the fan in this way, the belt is too tight. If the fan slips easily, the belt is too loose.

To change the tension of the belt, loosen the nut on the rear end of the fan shaft. Then raise the fan with a small lever to increase the tension or lower it to decrease the tension. Be sure to tighten the nut after the correct tension has been secured.

Radiator and Shutters

The radiator consists of an upper tank and a lower tank connected by water passages, around the outside of which air is circulated by the fan. The water passages are so constructed that they expose a large amount of surface to the air, which cools the water as it passes from the upper to the lower tank. Until the water in the cylinder blocks and radiator is warm, the cooling effect of the radiator is not only unnecessary but undesirable. The radiator is accordingly provided with shutters that prevent air from circulating around the water passages until the engine becomes warm. The shutters are pivoted vertically and are controlled automatically by a powerful thermostat contained in the upper tank of the radiator.

When the engine is cold, the shutters are held tightly closed and circulation of air is prevented. The water from the cylinders consequently undergoes little change in temperature as it flows through the radiator, and the engine quickly becomes warm. As soon as the water entering the upper tank of the radiator reaches the temperature at which the engine operates best, the shutters are forced open by the thermostat and air begins to circulate. The resulting cooling effect checks the rising temperature of the water, which is thereafter maintained uniformly at the temperature of most efficient operation as long as the engine is running. (See "Temperature Indicator," page 10.)

Radiator Thermostat

There is no adjustment in connection with the radiator thermostat. The thermostat is filled and sealed at the factory, the liquid determining the temperature at which the thermostat operates.

Water Pump

The water pump shaft is packed against leakage by a gland which can be tightened by turning the gland nut. This nut is held from turning of its own accord by a locking plunger. To tighten the gland nut, first remove the oil filler, then lift this plunger, and with a screw-driver or punch, turn the top of the nut toward the engine. Do not tighten the nut more than just enough to prevent leakage. Further tightening causes unnecessary friction on the pump shaft.



Figure 40. View looking down on water pump. The water pump packing nut should be tightened only enough to prevent leakage.

Filling and Draining the Cooling System

Except during freezing weather, water should be used in the cooling system. In freezing weather, a suitable anti-freezing solution, such as those described on page 40, must be used.

To add liquid to the cooling system or to refill the cooling system after it has

been drained, remove the radiator filler cap and pour the liquid in through the filler.

It is not necessary to add liquid to the radiator whenever the level falls below the filler. There is sufficient liquid in the cooling system if the upper tank of the radiator is half full, and any liquid in excess of this is usually forced out through the overflow pipe as soon as the engine becomes warm. When water is used, any loss from this cause is of little consequence, but in winter, to conserve anti-freeze, it is important to avoid adding more liquid than is necessary.

To drain the cooling system, open the drain valve in the water pump outlet elbow by turning the hexagonal end of the valve counterclockwise.

Cleaning the Cooling System

The cooling system should be drained and flushed every 4000 miles. If possible, this should be done at a Cadillac service station or where there are facilities for reversing the flow of water through the radiator. If this is not possible, use the following method:

Run the engine until the opening of the radiator shutters indicates that the engine is warm. Stop the engine and immediately open the water pump drain valve.

After the liquid has drained off, refill the cooling system with hot water and repeat the operation described above. If in draining the second time, the water is very dirty it may be advisable to repeat the flushing operation a third time, placing one or two handfuls of sal-soda in through the radiator filler. The sal-soda must not be permitted to get on the finish of the hood or radiator. If sal-soda is used, the cooling system must be drained and flushed again before refilling for use.

CHAPTER IV

Electrical System

THE electrical system comprises the following units: The generator, or source of electrical energy; the storage battery, which stores the energy generated; the starting motor, which cranks the engine for starting; the ignition system; the lamps and other devices using electrical current; the ammeter; the ignition and lighting switch; and the circuit breakers, which protect the system. The wiring system connecting these units is the single-wire or grounded type, the engine and frame forming one side of the electrical circuit.

Generation of Current

Generator

The generator is below the right-hand cylinder block at the front of the engine, and is driven by a silent chain from the crankshaft.

At very low engine speeds, the voltage of the current generated is not sufficient to provide current for lighting or ignition, and the battery is then the source of current. To prevent the battery, at such times, from discharging through the generator, a cut-out relay on the generator automatically opens the circuit whenever the generated voltage drops below the battery voltage. At approximately eight miles per hour, the generated voltage is sufficient to operate the cut-out, which then closes the circuit between the generator and the battery and lighting circuits. If no lights are switched on, the entire output of the generator, less the current required for ignition, flows to the battery for recharging it. If all the lights are on, the generator will not generate sufficient current to start charging the battery until a speed of twelve to fifteen miles per hour is reached.

Ammeter

The ammeter on the instrument board indicates the amount of current flowing to or from the battery, except when the starter pedal is down and the starting motor is cranking the engine. When the engine is not running, the ammeter will indicate a current on the discharge side, depending in amount upon the number of lights in use. The rate of charge or discharge when the engine is running depends upon the speed of the engine, whether the thermostat is opened or closed and how many lights are in use, and is equal in amount to the difference between the current generated and the current used by the

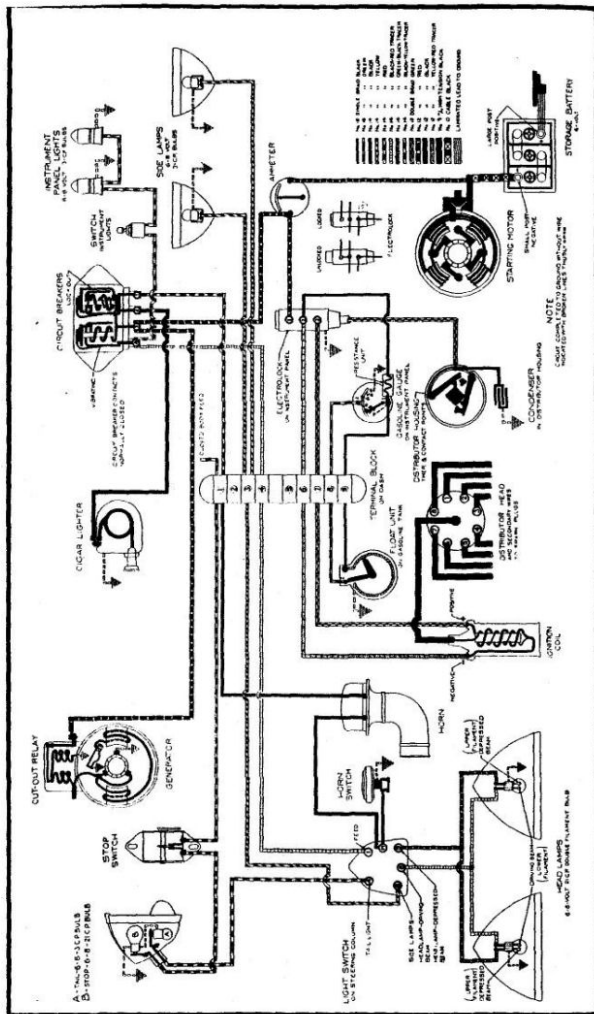

Fig. 17. La Salle circuit diagram.

lights, horn, ignition, and other electrical devices. The ammeter does not indicate the current used in cranking the engine.

Thermostatic Control of Charging Rate

The generator is provided with a thermostatic control. This is so arranged that the amount of current generated is automatically reduced as soon as the temperature of the generator rises above a predetermined point. When the engine is cold the charging rate is normal. When, due to the combined heat of the engine and the generator, the temperature of the generator reaches the predetermined point, the thermostat operates and the charging rate is correspondingly reduced.

The purpose of this is to give the battery, as quickly as possible, the energy used for starting or for the lights while parking. This also compensates in a measure for seasonal variations, because in cold weather, when the demand on the battery is greater, a longer period elapses after starting the engine before the thermostat operates to reduce the charging rate. It is thus unnecessary to have a different adjustment of the charging rate for winter from that for summer.

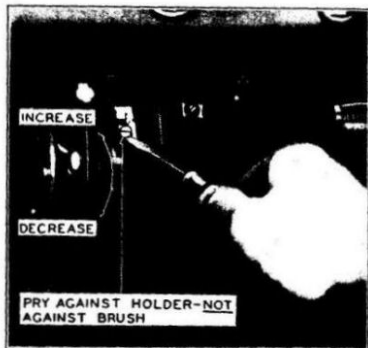

Figure 42. The charging current is adjusted by moving the third brush. This must be done when the engine is cold.

Adjustment of Charging Rate

The charging rate must be checked and adjusted before the engine is warm enough for the thermostat to open. All the lights must be off. Start the engine and open the throttle until the ammeter reading ceases to increase and starts to decrease. The maximum reading should not be more than 18 amperes, and ordinarily not less than

16. In no case should the maximum reading exceed 20 amperes.

These figures are for a cold engine. If the charging rate is adjusted to these figures when the thermostat is open, damage is likely to result to the generator.

The amount of the charging rate is adjusted by changing the position of the third brush on the generator commutator. This brush is accessible after removing the cover band around the rear end of the generator (Fig. 42). The brush holder is held by friction and can be moved by prying it. Do not pry against the brush itself, and be very careful not to spring the brush holder.

Do not under any circumstances put oil on the commutator of the generator.

Storage Battery

The storage battery is a three-cell, six-volt Exide battery made especially for the La Salle electrical system by the Electric Storage Battery Company of Philadelphia, Pennsylvania. The battery com-

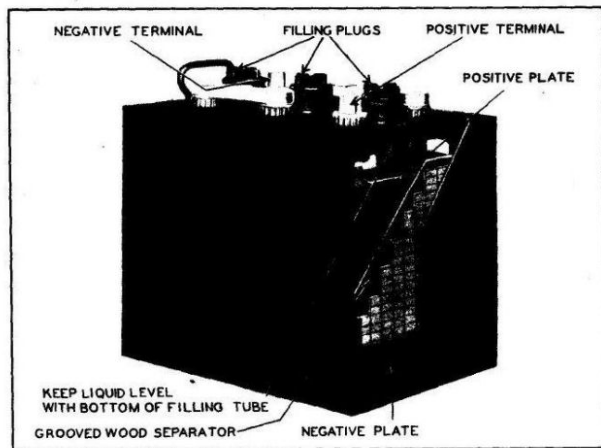

Figure 43. The storage battery is under the right-hand end of the front seat.

partment is attached to the right-hand side bar of the frame under the front seat. To have access to the battery, remove the seat cushion,

unscrew the four wing nuts which hold the cover plate, and lift up the cover plate.

Adding Water to Storage Battery

The battery is filled with a solution from which the water slowly evaporates, and fresh distilled or other approved water must be added at intervals to maintain the correct level. The level should be inspected at least every 1000 miles, and in warm weather every 500 miles or at least every two weeks. Distilled or other approved water should be added to bring the level up to the bottom of the filling tubes.

Each cell is provided with a filling tube and vent plug. To remove a vent plug, turn it as far as possible counter-clockwise and then lift it straight up. To install it, set the plug in place and turn it clockwise until tight. If a plug is lost or broken, obtain a new one and install it as soon as possible.

Nothing but pure distilled or other approved water should be added to the battery solution. Melted artificial ice or rain water caught in an earthenware receptacle may be used. Hydrant water or water that has been in contact with metallic surfaces will cause trouble if used. Acid must never be added to the battery.

After adding water to the storage battery in freezing weather, the car should immediately be run far enough to mix the water and acid solution thoroughly. If the car is parked immediately after adding water, the water is likely to stay on top of the acid solution and may freeze, causing extensive damage.

If one cell regularly requires more water than the others, a leaky jar is indicated. A leaky jar should be replaced immediately by a new one, as even a very slow leak will in time result in the loss of all the solution in the cell.

Specific Gravity of Battery Solution

As the storage battery is charged and discharged, the solution reacts chemically with the plates of the battery, the specific gravity of the solution changing as the reaction proceeds. The state of charge of the battery is thus indicated by the specific gravity of the solution. As the battery is charged, the specific gravity of the solution increases, reaching 1.270 to 1.285 when the battery is fully charged. The specific gravity of the solution decreases as the battery is discharged. A fully discharged battery has a specific gravity of 1.150 to 1.165.

A hydrometer is the instrument used to measure the specific gravity of a solution. A hydrometer syringe is a hydrometer especially de-

signed for convenience in testing the specific gravity of the acid solution in the storage battery. A hydrometer syringe can be obtained at any battery service station. Be sure and get a reliable instrument, for cheap ones may be in error as much as 25 or 30 points.

The specific gravity of the acid solution should never be tested immediately after adding distilled water. If the solution is below the plates so that it cannot be reached with the syringe, add the necessary amount of water and then drive the car for a few hours before taking the hydrometer reading.

Disconnecting Battery

Do not remove the generator or attempt any adjustment of the circuit breakers or remove any of the wires to the circuit breakers without first disconnecting the storage battery.

Never run the engine with the storage battery disconnected. Serious damage to the generator may result.

Exide Depots and Sales Offices

The Electric Storage Battery Company, whose general offices and works are at Allegheny Avenue and Nineteenth Street, Philadelphia, Pennsylvania, has representative stations in towns of any considerable size, as well as sales offices and Exide battery depots in a number of the larger cities. If a storage battery is in need of attention other than recharging, it is advisable to communicate either with a Cadillac service station or with the nearest Exide station or depot. Do not ship a storage battery without receiving instructions.

Starting Motor

Operation of Starter

The starting motor is a series-wound motor, mounted horizontally at the right-hand side of the transmission case. When cranking the engine, the starting motor drives the flywheel through a pinion which meshes with teeth machined on a ring bolted to the flywheel. The pinion is normally held out of engagement with the teeth on this ring. It is moved into mesh with the teeth on the ring by pushing forward on the starter pedal. Further movement of the pedal operates a switch that closes the battery circuit and starts the armature revolving.

If, in pushing down the starter pedal, the ends of the teeth on the pinion strike against the ends of the teeth on the flywheel ring, preventing further movement of the pinion, continued movement of the pedal

compresses a spring. As soon as the pedal has been pushed down far enough to close the starting switch, the armature starts to revolve. The pressure of the spring then forces the pinion the rest of the way, completing the meshing operation.

An over-running clutch on the armature shaft prevents the fly-wheel from driving the starting motor after the engine is running under its own power and before the starter pedal is released.

Ignition

General Description

The function of the ignition system is, first, to multiply the low voltage (six to eight volts) of the storage battery and generator into voltage of sufficient intensity to cause a spark to jump between the electrodes of the spark plugs; and second, to time this spark so that ignition will take place in the proper cylinder at the proper instant.

The Delco single-spark system is used, consisting of a combination timer-distributor unit in connection with a transformer or induction coil. The primary circuit, through which flows the current from the storage battery or generator, includes the primary winding of the ignition coil; the timer contact arms and points; and the condenser, which is enclosed in the timer. The secondary or high-voltage circuit includes the secondary winding on the ignition coil, the distributor and the spark plugs.

Current flows through the primary circuit whenever and as long as either of the two sets of timer contact points is closed. Current flows through the secondary circuit for an instant only when either set of contact points is opened; but the voltage of this current is several thousand times that of the primary circuit and is sufficient to cause a spark at the spark plug.

Timer-Distributor

The timer-distributor is mounted on the top of the crankcase at the front end and is driven by a spiral gear on the camshaft. The shaft of the timer-distributor, which revolves at one-half crankshaft speed, carries a four-lobed cam. As this cam revolves, it actuates the two contact arms alternately, closing and opening first one set of contact points and then the other. The circuit is thus made and broken eight times during each revolution of the cam and eight corresponding sparks are produced at the spark plugs.

In order to procure the maximum power from each explosion, ignition must occur at the right instant in relation to the position of the

piston. But the ignition process, although apparently a matter of an instant, consumes a measureable amount of time. It is therefore necessary to break the circuit at the contact points far enough in advance so that actual ignition will take place in the cylinder at the correct time. The lapse of time is always the same, regardless of the speed of the engine, but because the pistons move faster when the engine is running at higher speeds than when it is running at lower speeds, the degree of advance in relation to the positions of the pistons must be increased as the engine speed increases.

This advancing of the relative timing of the spark for higher engine speeds is automatically accomplished by a centrifugal ring governor on the timer shaft below the cam. As the speed of the engine increases, the governor ring assumes a position more nearly horizontal, forcing the cam ahead of the shaft by which it is driven. This causes the contact points to open earlier, starting the ignition process earlier in relation to the positions of the pistons in the cylinders.

In addition to the automatic advance, the timer has a manual control by which the opening of the contact points may be still further advanced or still further delayed. This is operated by a lever on the instrument board (Fig. 1).

The distributor is the mechanism that insures that the high voltage current in the secondary circuit is switched to the proper spark plug at the proper time. It consists of a rotor, which is carried on the upper end of the timer shaft and which has a metal terminal electrically connected at all times with the secondary current from the coil. As the rotor revolves, this terminal faces successively eight metal inserts in the distributor head, which is only a few thousandths of an inch from the rotor. The eight inserts are connected each to a different spark plug. When either set of timer contacts opens, the terminal in the rotor is directly opposite one of the inserts and the high voltage in the secondary circuit jumps from the rotor to the insert, and thence it is conducted to the corresponding spark plug. The relation between the rotor and the timer shaft is such that the spark plugs fire in correct relation to the pistons.

Adjustment of Contact Points

The gaps between the timer contact arms and the contact screws are accurately adjusted at the factory to the correct amount. As the rubbing blocks on the contact arms wear, however, the gaps decrease and eventually readjustment must be made, although ordinarily this is not necessary for many thousands of miles.

The correct gap is .027 inch. To adjust the contact points, turn the distributor shaft until the rubbing block of one of the contact arms is on one of the lobes of the cam. Then adjust the corresponding contact screw so that there is .027 inch gap between the points (Fig. 44).

After adjusting the gap for one set of contact points, turn the shaft until the rubbing block of the other contact arm is on one of the lobes of the cam, and adjust the other set of points.

It is not absolutely necessary to retime the ignition after adjusting the contact points, but it is recommended.

Timing Ignition

All timing of the ignition should be done with the spark control lever fully advanced.

Timing the ignition should not be attempted without making sure that both sets of contact points are correctly adjusted for gap as previously directed.

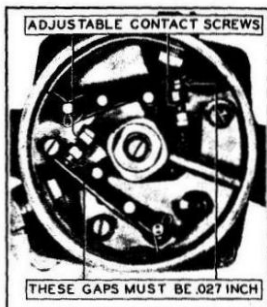

Figure 44 The timer contact points must be correctly adjusted to produce proper ignition.

Ignition for the odd-numbered cylinders is provided by one of the contact arms, this arm being mounted on a fixed plate. Ignition for the even-numbered cylinders is provided by the other contact arm, which is mounted on an adjustable plate (Fig. 47). The timing for the odd-numbered cylinders depends only on the position of the cam. The timing for the even-numbered cylinders depends both on the position of the cam and on the adjustment of the plate which carries the second arm. This plate is correctly adjusted at the factory and ordinarily will not need to be readjusted.

To check the timing for the odd-numbered cylinders, disconnect the wire from the spark plug for the No. 1 cylinder, and place the terminal of the wire so that it is about



Figure 45. Marks for timing the ignition are stamped on the flywheel.

$\frac{1}{8}$ inch from the cylinder block. Open the cover on the flywheel inspection hole at the rear of the right-hand cylinder block. Switch on the ignition and crank the engine slowly by hand until a spark jumps from the disconnected wire to the cylinder. Stop cranking at once and observe the position of the flywheel. The mark $\frac{1}{2}$ on the flywheel should then be opposite the pointer attached to the crankcase.

If the mark on the flywheel has passed the pointer, the ignition is late. If the mark has not reached the pointer, the ignition is early.

To correct the timing, loosen the screw in the center of the timer shaft. Then carefully turn the cam either with a wrench or with the rotor. Turn the cam clockwise to advance the ignition, or counter-clockwise to retard it. After moving the cam, tighten the screw and check by again cranking the engine and noting the position of the flywheel when the spark occurs.

To check the timing for the even-numbered cylinders, disconnect the

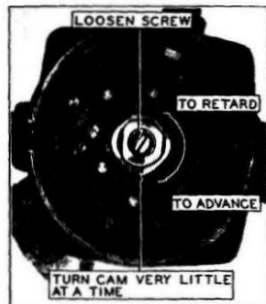

Figure 46. The ignition is timed by adjusting the cam on the timer shaft.

wire from the No. 2 spark plug. Then crank the engine by hand, the same as before, stopping the instant the spark takes place. The mark $\frac{1}{2}$ on the flywheel should then be opposite the pointer.

If the ignition for the odd-numbered cylinders has been carefully timed, the ignition for the even-numbered cylinders will ordinarily be correct. If it is not, it is best to have the distributor serviced at a Cadillac service station, where

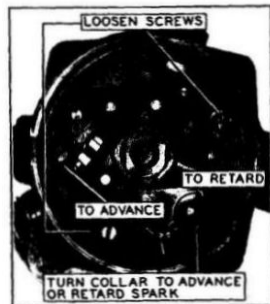

Figure 47. The contact arm for the even-numbered cylinders must be synchronized with relation to the contact arm for the odd-numbered cylinders.

If the car is equipped with high-compression cylinder heads (page 23), disregard the ignition timing marks on the flywheel and set the spark to take place $\frac{1}{8}$ inch ahead of center.

a gauge is available for setting the plate which carries the adjustable arm. In an emergency, however, the timing of the even-numbered cylinders can be corrected as follows:

Loosen the two screws shown in Fig. 47. Then carefully turn the eccentric adjusting collar with a screw-driver, turning the collar clockwise to retard the ignition and counter-clockwise to advance it. Be sure to tighten the screws after the correct adjustment has been secured.

Spark Plugs

For best results, the electrodes of the spark plugs should be .032 to .035 inch apart. If the spark plugs should be removed, it is recommended that the electrodes be inspected and adjusted to this clearance.

Lighting System

Lamp Bulbs

It is recommended that bulbs for the lamps, particularly the two-filament bulbs for the headlamps, be purchased from a Cadillac distributor or dealer. In any event, bulbs should have the correct voltage and candle-power ratings. Only three different types of lamp bulbs are used in the entire lighting system. The bulbs and the lamps in which they are used are as follows:

LAMP	VOLTAGE	CANDLE-POWER
Headlamps	6-8	21 (Two-Filament) Mazda No. 1110
Stop Light	6-8	} 3 21 (Single Filament)
Side Lamps	6-8	
*Instrument Lamps (2)	6-8	
*Rear Lamp	6-8	
Closed Car Dome Lamps	6-8	
**Running Board Step Light	6-8	

Cleaning Headlamp Reflectors

The headlamp reflectors are plated with pure silver. Although the reflectors ordinarily require no attention, if they should require polishing, extreme care must be exercised to select materials that will not scratch the silver. In polishing reflectors, always rub from the bulb outward, do not rub in circles.

Powdered dry rouge and a chamois skin are recommended. If the reflectors are tarnished, the rouge may be moistened with alcohol. Afterwards, polish with a dry chamois and rouge.

The chamois used for the headlamp reflectors must not be used for any other purpose. It must be soft and free from dust.

Do not touch the reflectors with the bare hands.

Adjustment of Headlamps

Approval of the headlamps by the state authorities is conditional upon the headlamps being adjusted to a definite standard. The directions which follow are for this standard adjustment.

*Bulbs rated at 3-4 volts, such as are used in the rear lamps of some cars, must not be used in these lamps. If installed, they will burn out almost immediately.

**Used only on cars with 134-inch wheelbase.



Figure 48. Double-filament headlamp bulb.

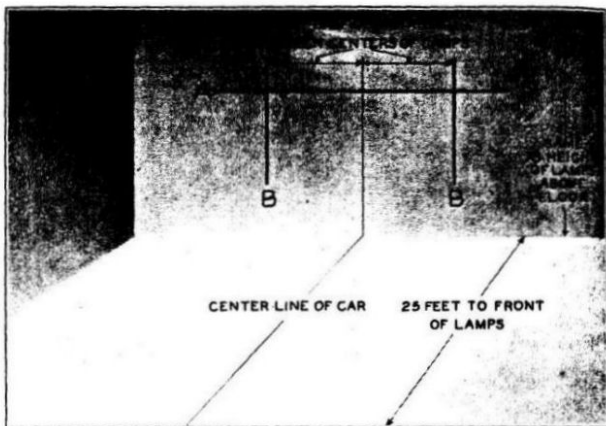

Figure 49. Marks for adjustment of headlamps

Select a level spot where the car can be placed facing toward, and twenty-five feet distant from, a wall upon which the lines shown in Fig. 49 can be drawn. The adjustment should be made when it is dark enough so that the outlines of the projected beams are plainly visible.

Locate a point on the wall directly opposite the front of the car by sighting through the center of the rear curtain toward the radiator cap. Draw a vertical line on the wall through this point. Measure the distance between the centers of the headlamps, and draw two vertical lines "B" parallel to the center line and distant from it by an amount equal to one-half of the distance between the headlamps. Measure the distance from the headlamp centers above the ground or floor and draw the horizontal line "A" at the same elevation.

The adjustment should be made with the upper beam on, that is, with the lighting switch lever at "Up." Cover the headlamp that is not being adjusted.

Turn the adjusting screw, which is in the back of the headlamp shell, until the small beam of high intensity at the top is most clearly defined. (Fig. 50a.) This focuses the lamp.

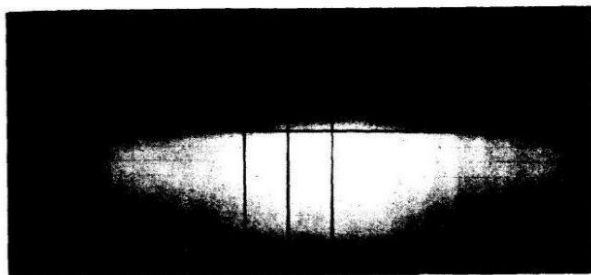

Figure 50a. Upper beam of right headlamp

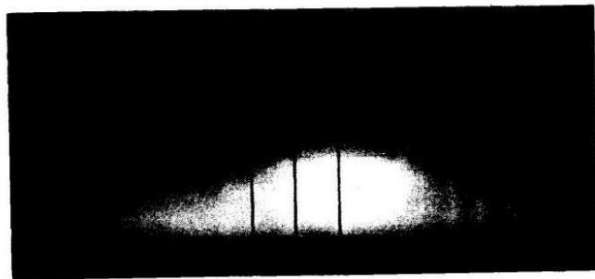

Figure 50b. Lower beam of same lamp

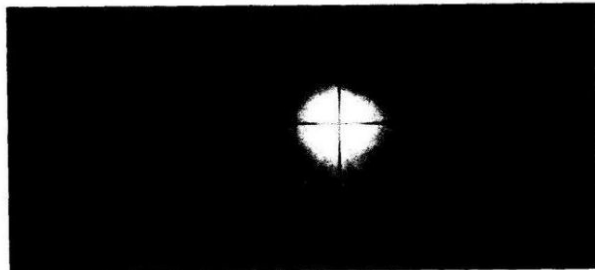

Figure 50c. Upper beam with lens removed

With the car fully loaded, loosen the nut on the headlamp support and aim the high intensity beam so that it is centered on the corresponding vertical line "B," with the upper part cut off on the horizontal line "A." (Fig. 50a.) Tighten the nut securely, taking care not to move the lamp out of adjustment.

No adjustment for the lower beam is necessary. If the lamp has been correctly focused and aimed with the upper beam on, the lower beam will appear as in Fig. 50b.

If it is desired to focus the lamp with the door removed, this can be done. Fig. 50c shows the upper beam as it should appear with the lens removed.

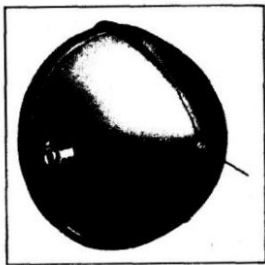

Figure 51. Headlamp adjusting screw

CHAPTER V

Clutch and Transmission

Clutch

The La Salle clutch is a disc clutch of exclusive design. There are three driving plates, the center plate being bolted to the flywheel. The front and rear driving plates float or slide on pins carried by the center plate.

There are two driven discs, one between the center and rear driving plates and the other between the center and front driving plates. Both discs are bolted to a central hub which slides on the splined end of the clutch shaft. The discs are fan shaped and are lined on both sides with a ring of friction material.

When the clutch is engaged, the plates and discs are pressed firmly together under the pressure of twelve 70-lb. springs. The driven discs then revolve with the flywheel, and the engine, if running, drives the transmission.

When the clutch pedal is pushed down to disengage the clutch, a series of levers releases the pressure of the springs and the driven discs separate from the driving plates, permitting the flywheel to revolve independently of the clutch and transmission.

The clutch itself requires no adjustment or attention other than lubrication of the clutch thrust bearing, as directed on page 55. Adjustment of the clutch release rod, however, may be necessary after the car has been driven some distance.

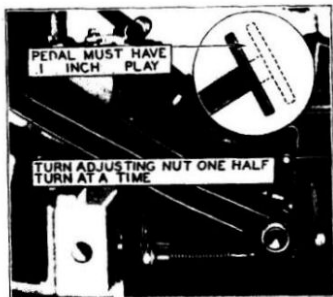

Figure 52. The clutch control must be adjusted so as to give the clutch pedal proper play.

Adjustment of Clutch Release Rod

As described on page 16, the clutch pedal is purposely given about one inch of "lost motion." That is, the clutch does not begin to disengage until the pedal has been moved down about an inch from its released position. This lost motion is necessary in order to allow the clutch discs and plates to come closer together as the facings are reduced in thickness. The lost

motion gradually decreases as the clutch is used, and eventually will be taken up. Before this happens, the clutch release rod must be readjusted to restore the lost motion; otherwise the clutch discs will slip and the engine will not drive the car.

To make the adjustment, unscrew the nut (Fig. 52) on the end of the rod until the clutch pedal has a movement of one inch without starting to disengage the clutch.

The nut must be turned a half-turn at a time.

Transmission

The purpose of the transmission is to provide a means for varying the ratio and direction of the rear axle speed in relation to the engine speed. Three things are accomplished by doing this: First, the engine is enabled to drive the car backwards. Second, the engine is permitted to revolve fast enough to develop the power necessary for starting and for driving the car at extremely low speeds. Third, the turning effort of the engine is multiplied, so that it may be sufficient for climbing steep hills and pulling through deep sand and mud.

The La Salle transmission is known as the selective, sliding gear type. It has three speeds forward, of which one is direct drive, and one speed in reverse. Selection of the various speeds is accomplished by movement of two shipper gears (Fig. 53) which are controlled by the transmission control lever.

The positions of the gears corresponding to the five positions of the control lever, as illustrated in Fig. 8, are as follows:

Neutral—When the control lever is in neutral position, the shifter gears are in the positions shown in Fig. 53, that is, they are not in mesh with any of the other gears.

Low—When the control lever is moved from neutral to low, the low and reverse shipper gear is moved forward into mesh with the low gear on the jackshaft. The ratio of engine speed to propeller shaft speed in low is approximately 3 to 1.

Intermediate—When the control lever is moved from low to intermediate, the low and reverse shipper gear is first returned to its neutral position and the high and intermediate shipper gear is then moved back into mesh with the intermediate gear on the jackshaft. The ratio of engine speed to propeller shaft speed in intermediate is approximately 1.7 to 1.

High—When the control lever is moved from intermediate to high, the high and intermediate gear is first moved forward out of mesh with the intermediate gear on the jackshaft, and then farther forward until teeth, cut internally in a recess in the high and intermediate shipper gear, engage teeth on the extreme end of the gear on the clutch shaft. The drive is then direct from the clutch shaft to the transmission main shaft without reduction.

Reverse—When the control lever is moved from neutral to reverse, the low and reverse shipper gear is moved back into mesh with an idler gear, which is at all times in mesh with the reverse gear on the jackshaft. The interposition of the idler gear reverses the direction of rotation. The ratio of engine speed to propeller shaft speed in reverse is approximately 3.7 to 1.

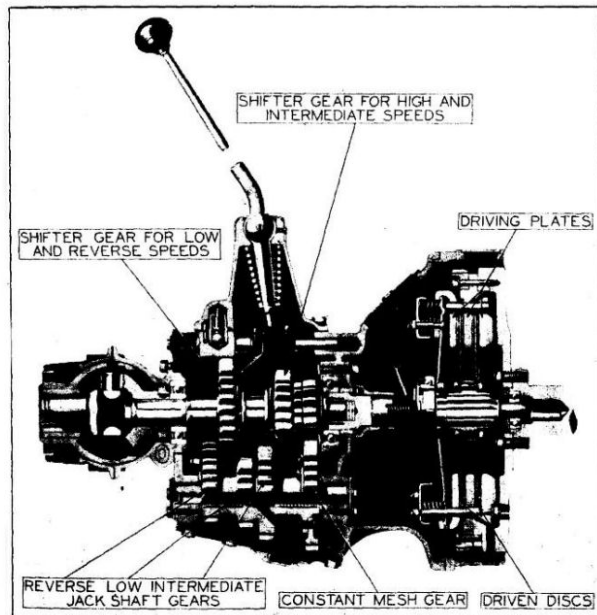

Figure 53. Sectional view of clutch, transmission and universal joint

Steering Gear

Description

THE La Salle steering gear is of the worm and sector type. In this construction, the tube or shaft, to which the steering wheel is fastened, has on its lower end a worm which engages a sector gear. The steering arm is fastened to the shaft of this sector gear.

The steering gear has three adjustments: one to adjust the position of the sector in its relation to the worm; a second to take up end-play in the worm thrust bearings; and a third to take up end-play in the sector shaft.

Adjustment of Worm and Sector

This adjustment consists in moving the sector away from or toward the worm, so as to give the proper amount of backlash. Provision is made for doing this by means of the sleeve or bushing in which the sector shaft turns. The outside of this bushing is eccentric, and by turning the hexagonal end of the bushing, which projects through the side bar of the frame, the sector can be moved away from or toward the worm. To make the adjustment, proceed as follows:

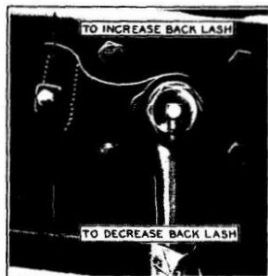

Figure 54. This adjustment is to take up backlash between the worm and sector.

Turn the steering wheel so that the front wheels point straight ahead. Loosen the locking screw shown in Fig. 54. Then move the locking arm down to tighten the adjustment, or up to increase the backlash. The steering wheel should have from one-half to three-quarter inch play. If the amount of backlash to be taken up is very great, it may be necessary to remove and replace the locking arm in a different position on the hexagonal end of the eccentric bushing, in order to bring the locking arm in such a position that it can be locked by the screw.

(100)

Adjustment of Worm Thrust Bearings

To take up end-play in the worm thrust bearings, first back off the worm and sector adjustment (described in the preceding section) and loosen the cap on the support bracket on the instrument board. Loosen the clamping screw shown in Fig. 55. Then with a large wrench turn the adjusting nut until all play in the bearings is taken up. Tighten the clamping screw and the cap on the instrument board after the proper adjustment has been made. Finally, take up the worm and sector adjustment again.



Figure 55. This adjustment is to take up end-play in the worm thrust bearings.

Adjustment of Sector Shaft

The third adjustment is to take up end-play in the sector shaft. This adjustment is on the rear cover of the steering gear housing and is rarely necessary.

To make the adjustment, loosen the lock nut shown in Fig. 56, and turn the adjusting screw until the end play is taken up.



Figure 56. This adjustment is on the cover plate of the steering gear housing, and is to take up end play in the sector shaft.

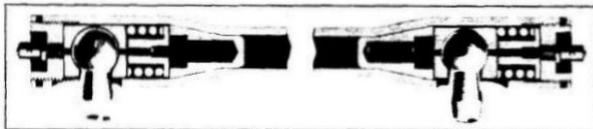

Figure 57. To adjust the joints at the ends of the steering connecting rod, draw each adjusting plug tight and then back it off one cotter pin hole.

Steering Connecting Rod

The steering connecting rod, which connects the steering arm at the steering gear with the steering arm on the front axle, has a ball and socket joint at each end. Wear at these joints can be taken up by adjusting the screw plugs in the ends of the rod. The plugs should be screwed in tight and then backed off one cotter pin hole.

CHAPTER VII

Front Axle

Description

THE La Salle front axle is of the reverse-Elliot type, in which the spindles are yoked or forked to receive the ends of the center member of the axle. The bolts on which the spindles pivot are keyed in the axle and turn in bronze bushings in the spindle. The thrust is taken by a ball bearing in the lower fork of the spindle.

Stop Screws

It is desirable to have the smallest turning radius possible without the front wheels scraping at any point on the chassis.

To prevent such interference, stop screws (Fig. 58) are provided on the ends of the axle. The stop screw at the right-hand end of the axle limits the angle to which the wheels can be turned to the right. The stop screw at the left-hand end of the axle limits the angle at which the wheels can be turned to the left.



Figure 58. The stop screws at the ends of the front axle should be adjusted so as to prevent the tires from scraping on the chassis.

Alignment of Front Wheels

The correct amount of toe-in for the front wheels is not less than $\frac{1}{8}$ inch nor more than $\frac{1}{4}$ inch. Every reliable garage has a gauge for measuring this distance. In the absence of such a gauge, it may be measured in the following manner:

Pull the car forward one or two feet. Then spread the wheels as far apart as possible by pushing on both tires at the same time. This will duplicate in the steering connections the conditions that exist on the road.

Locate on the side of each tire a point approximately 9 inches above the floor, and at the widest part of the tire, marking this point with chalk (Fig. 59). Measure the distance between these two points, using a tape measure or two yard-sticks placed so they overlap.

Pull the car forward until the two chalk marks pass under the axle and are again 9 inches above the ground, but to the rear instead of in front of the axle. Then measure the distance between the two chalk marks again. The difference between the two measurements should be not less than $\frac{1}{8}$ inch nor more than $\frac{1}{4}$ inch.

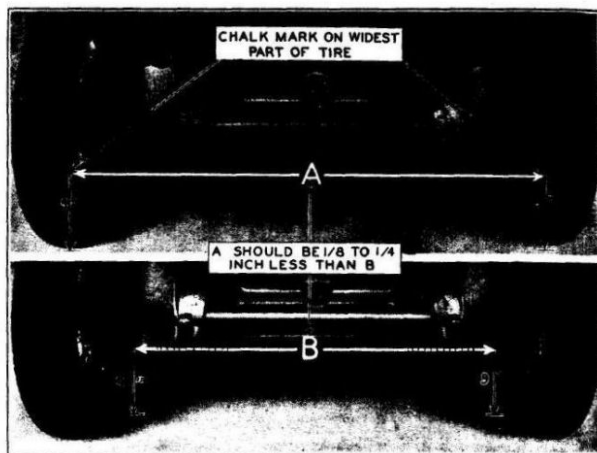

Figure 59. Alignment of the front wheels is important to give proper steering and prevent excessive tire wear.

Adjustment of the front wheel alignment is made by loosening the clamp screws at the ends of the parallel rod and turning the rod, which has right-hand threads at one end and left-hand threads at the other.

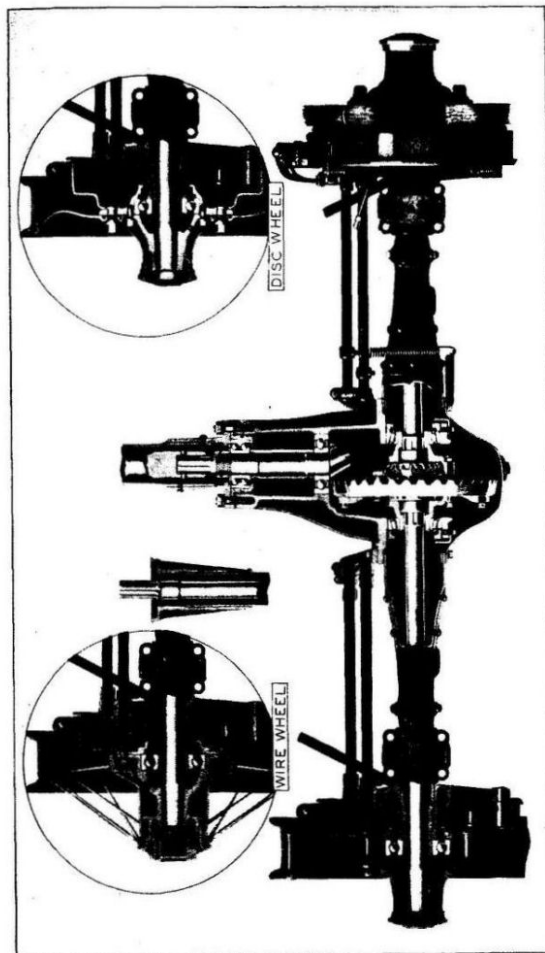

Figure 60. Sectional view of rear axle with wood wheel, wire wheel and disc wheel.

CHAPTER VIII

Rear Axle and Torsion Tube

The rear axle is of the three-quarter floating type. The flanges on the outer ends of the axle shafts are bolted to the wheel hubs and the inner ends of the shaft are splined to fit the holes in the differential gears. The ring gear mount, which contains the differential, is mounted on tapered roller bearings supported by the differential carrier. The pinion shaft is mounted on ball bearings in the differential carrier.

Except for lubrication as described in Part II, the rear axle requires no attention. The rear axle gears are correctly adjusted at the factory and no attempt should be made to readjust them. If attention appears to be required, a Cadillac service station should be consulted.

The tractive effort of the rear wheels is transmitted to the car through a torsion tube which encloses the propeller shaft and which is bolted at the rear end to the differential carrier and at the front end to a ball and socket joint on the transmission. The torsion tube is trussed by strut rods running diagonally to the ends of the rear axle housing.

CHAPTER IX

Wheels

Tire Balancing Marks

The tires are balanced to offset the weight of the valve stem. If a tire is removed, it must be re-installed in its original position with respect to the rim; otherwise the tire and wheel will be unbalanced.

A small red square is accordingly branded in the rubber on the side of each tire. This mark must always be in line with the valve stem.

Removing Front Wheel

To remove a front wheel (wood type) first jack up the axle until the wheel is free from the ground and then proceed as follows:

Remove the hub cap by unscrewing it. Remove the cotter pin in the spindle and unscrew the nut. The nut on the right-hand spindle has right-hand threads and the nut on the left-hand spindle has left-hand threads. Remove the washer. The wheel may then be removed by pulling it straight off.

To remove the inner hub of a front *wire* wheel, first remove the wheel from the hub. Then unscrew the dust cap which is just inside the hub. This will give access to the nut on the spindle.

To remove a *disc* wheel, with hub, from the spindle, proceed the same as for a wood wheel.

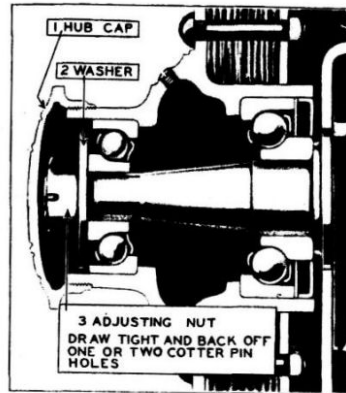

Figure 61. Front wheel bearings should be adjusted too loosely rather than too tightly.

Installing Wheel

Before installing the wheel, make sure that the bearings are cleaned and that they are packed in light grease that is free from dirt and grit.

Set the wheel in place on the spindle, install the washer and draw up the adjusting nut just tight enough to make sure that the bearing races are seated.

Back off the nut slowly until it is possible to feel a slight shake in the wheel.

Draw the nut up again until the next cotter pin slot in the nut lines up with the cotter-pin hole in the spindle.

Spin the wheel, making sure that all parts are in correct position, then insert the cotter pin and clinch it securely.

In order to avoid mistaking play in the spindle bolt for play in the wheel bearings, it is a good plan to insert a wedge between the spindle and the end of the axle.

Rear Wheels

Rear wheel bearings are not adjustable and there should be no occasion for the removal of the rear wheels.

Brakes

General Description

There are three pairs of brakes: The rear wheel external brakes, the rear wheel internal brakes, and the front wheel brakes, which are also internal. The rear wheel external brakes and the front wheel brakes are operated by the brake pedal and comprise the foot brakes. The rear wheel internal brakes are operated by a hand lever and are used principally for locking the rear wheels when the car is standing.

The purpose of the front wheel brakes is to add to the braking ability as much as is consistent with safety. It is not desirable to attempt to secure the maximum possible braking effect on the front wheels for the reason that, when a front wheel slides without rotating, it has no power to change the direction of the car.

La Salle front wheel brakes are accordingly designed so that when the foot brakes are applied while the steering wheel is turned to the right or left, only the brake on the inside wheel is effective and the brake on the outer wheel is released, leaving the outer wheel free to rotate. It is thus impossible to lock both front wheels even on slippery pavement unless the car is moving straight ahead. If, while the car is moving straight ahead on slippery pavement, the brakes should be applied with sufficient pressure to lock both front wheels and it then becomes necessary to make a turn, the car will instantly respond because the brake on the outer wheel is automatically released as soon as the steering wheel is turned.

Brake Adjustment

When the brake pedal must be pushed down to within one inch of the floorboard in order to fully apply the brakes, it is time for the brakes to be readjusted. The brakes should then be completely readjusted, that is, both front and rear brakes should be taken up to compensate for the wear that has taken place.

In an emergency, however, the rear brakes can be taken up in the manner described in the following paragraph so as to serve until the complete adjustment can be made, which should be as soon as possible thereafter.

Temporary Adjustment

When time or facilities are lacking for a complete adjustment of the brakes, a temporary adjustment can be made by taking up one or two turns on the upper and lower nuts shown at (4) and (5) in Fig. 62. A wrench is provided in the tool equipment for this adjustment.

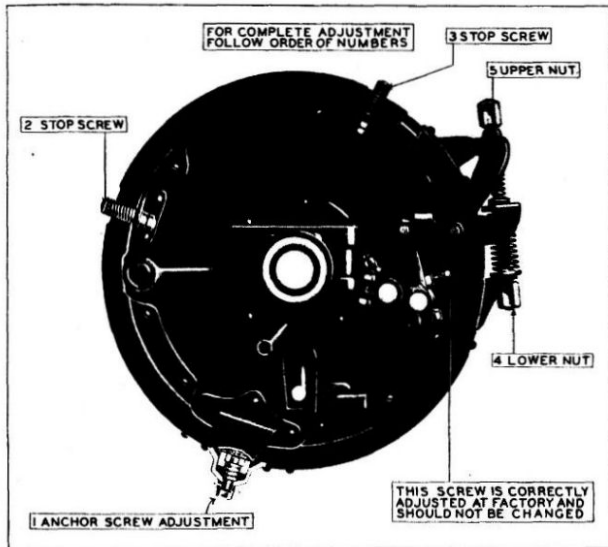

Figure 62. The left-hand rear foot brake as viewed from under the car. The five adjustments should be made in the order shown. The object is to have a uniform clearance of .035 between the lining and drum.

This temporary adjustment must be followed by a thorough adjustment of both front and rear brakes as soon as possible.

Adjustment of Rear Wheel Brakes

The most important thing in adjusting brakes is to secure the proper uniform clearance between the brake lining and the drum. A feeler .025 inch thick should be used to test the clearance.

The first adjustment is that of the anchor adjusting screw (1, Fig. 62). Adjust this screw until the clearance between the brake drum and those parts of the lining nearest the anchor is .025.

Second: Adjust the stop screws (2 and 3) which are above the upper part of the brake band so that there is .035 inch clearance between this part of the band and the brake drum.

Third: Adjust the nut (4) on the lower end of the adjusting rod so that there is .025 inch clearance between the lower part of the brake band and the drum.

Fourth: Adjust the nut (5) on the upper end of the rod so that the end of the upper part of the brake band has .035 inch clearance.

Fifth: After a uniform clearance of .025 inch has been secured, the results should be checked by applying the brakes and measuring the travel of the lower end of the lever at the band. This travel should be $\frac{3}{4}$ to $\frac{11}{16}$ inch. If the end of the lever travels more than $\frac{11}{16}$ or less than $\frac{3}{4}$ inch, the adjustments should be repeated, increasing or decreasing the clearance as required.

This procedure should be followed first on one brake, then on the other.

Do not change the adjustment of the rods which operate the rear wheel brakes. The rear brakes should be adjusted only by the screws and nuts described. The brake rods are correctly adjusted at the factory and should not be tampered with.

Adjustment of the front wheel brakes is usually not necessary until the rear wheel foot brakes have been adjusted several times. When this adjustment becomes necessary, it is recommended that the car be taken to an authorized Cadillac service station.

CHAPTER XI

Repair Parts

Genuine La Salle Parts

La Salle owners are cautioned against permitting the use of other than genuine La Salle parts in the repair of their cars. The quality of the La Salle car is identical with the quality of its component parts, the production of which is based upon the more than twenty-five years experience of the Cadillac Motor Car Company in designing, manufacturing, and inspecting. No other individual or organization has access to the data resulting from this experience nor could they possibly have the same interest in protecting the owners of La Salle cars.

Uniform Parts Prices

La Salle parts are sold at uniform prices throughout the United States, and are not subject to the addition of handling, excise or other supplementary charges. Printed price lists published by the Cadillac Motor Car Company are open to inspection by owners at any authorized Cadillac distributor's or dealer's establishment.

Ordering New Parts

It is obviously impractical for the factory to deal directly with each one of the many La Salle owners. We cannot open accounts with any except regular distributors with whom annual contracts are made.

To avoid unnecessary delay and correspondence, new parts should, where possible, be ordered from the distributor or dealer from whom the car was purchased or from the nearest Cadillac distributor or dealer, who carries a large stock and is generally in a position to supply a part immediately. If he cannot do so, he can order it. Where, however, conditions are such as in our judgment to warrant it, we will fill orders for parts at current list prices, f. o. b. factory, provided the order is accompanied by cash.

In ordering parts, either from a Cadillac distributor or from the factory, send the engine number and the unit assembly number (see page 113) with an accurate description of the part desired, preferably accompanied by a sketch with dimensions. If this cannot be done, send the part itself properly tagged and with transportation charges prepaid. (See below under "Returning Parts.") Otherwise prompt and intelligent filling of the order will be impossible.

Our responsibility ceases in all cases with delivery to the transportation company.

Returning Parts

In the event parts are returned, transportation charges must be prepaid or the parts cannot be accepted. They should be tagged properly with the name of the owner and the engine number of the car. A letter should be sent, giving complete instructions regarding the disposition of the parts.

Tires, Speedometer and Clock

In case of repairs to tires, speedometers or clocks, correspondence should be opened with the manufacturers or their representatives. If necessary, the parts should be sent to them. Transportation charges should be prepaid.

CHAPTER XII

Specifications and License Data

Type of engine.....	8 cyl. V-type
Diameter of cylinder bore.....	3 $\frac{1}{8}$ in.
Length of stroke.....	4 $\frac{1}{16}$ in.
Piston displacement.....	303 cu. in.
Horsepower (N. A. C. C. rating).....	31.25
Engine number.....	See below
Diameter of crankshaft main bearings.....	2 $\frac{3}{8}$ in.
Exhaust valves.....	1 $\frac{1}{2}$ in.
Inlet valves.....	1 $\frac{1}{2}$ in.
Capacity of gasoline tank.....	20 gals.
Capacity of engine lubricating system.....	2 gals.
Capacity of cooling system.....	5 $\frac{1}{4}$ gals.
Capacity of transmission.....	1 $\frac{1}{2}$ qts.
Capacity of rear axle.....	3 qts.
Wheelbase.....	125 in. and 134 in.
Tires (125 in. wheelbase).....	32x6.00 (low pressure)
(134 in. wheelbase).....	32x6.20
Tread.....	56 in.

Engine and Unit Assembly Numbers

EACH La Salle car when shipped carries an *engine number* which is also a serial number. This is the number to be used in filling out license and insurance applications and in general reference to the car. The engine number is stamped on the car in two places: On the name plate on the front face of the left side of the dash and on the crankcase just below the water inlet on the right-hand side.

The various units such as the transmission, steering gear, etc., also carry unit assembly numbers. These are located as described below. It is important in ordering parts to give, not only the engine number of the car, but also the unit assembly number of the unit to which the part belongs.

Transmission number—on the front surface of the support for the clutch pedal spring, or on either the top or the left-hand edge of the flange by which the transmission is bolted to the crankcase.

Steering gear number—on the steering gear housing, just below the grease gun connection.

- Carburetor number**—on right front face of the flange by which the carburetor is attached to the intake header.
- Generator number**—on the side of the generator just in front of the cut-out relay.
- Starting motor number**—on the right-hand side of the starter, just below the switch.
- Front axle number**—on the upper surface of the axle I-beam at the right-hand end just above the steering stop screw.
- Rear axle number**—on the rear surface of the axle housing just to the right of the cover plate.
- Chassis (frame) number**—on the upper surface of the left-hand side bar opposite the steering gear, or on the upper surface of the right-hand side bar opposite the crankcase support arm.

The Cadillac Motor Car Company reserves the right without notice to make changes in design, construction and specifications.

Index

- A**
- Accelerator (see throttle control) 10
- Accelerator, use of before engine is warm 42
- Adding water to storage battery 86
- Adjustment of brakes 108
- Adjustment of carburetor 75
- Adjustment of clutch release rod 97
- Adjustment of generator charging rate 84
- Adjustment of headlamps 93
- Adjustment of steering gear 100
- Adjustment of timer contact points 89
- Alcohol as anti-freeze 38
- Alcohol, effect of, on finish 39
- Alignment of front wheels 103
- Ammeter 19
- Ammeter, its use 83
- Anti-freezing solutions 38
- Axle, front 103
- Axle, rear 106
- Axle, rear, add lubricant to 55
- B**
- Balancing marks on tires 106
- Battery, storage 85
- Bearing, clutch thrust, to grease 55
- Bearings, main and connecting rod 68
- Bearings for wheels, adjustment of 106
- Body, care of 58
- Brake adjustment 108
- BRAKES 18, 108
- Brakes, general description of 108
- Bulbs for lamps, voltage 93
- Button, carburetor enriching 11
- C**
- Carbon, removal of 69
- Carburetor, adjustment of 76
- Carburetor enriching button 11
- Carburetor enriching button, use of in cold weather 41
- Carburetor, to prime 41
- Capacity of cooling system 39
- Caps, tire valve 30
- CARE OF BODY 58
- Care of finish on body when new 58
- CARE OF TIRES 61
- Chains 71
- Chains for tires, when improperly adjusted 61
- Changing tires 34
- Changing tires, use of jack in 34
- Chassis lubricant 47
- Chassis lubrication diagram 54
- Choke rod 11
- Choke rod button (carburetor enriching button) use of in cold weather 41
- Cigar lighter 27
- Circulating system for oil 48
- Circulation of water 79
- Cleaner for windshield 27
- Cleaning headlamp reflectors 93
- Cleaning the cooling system 81
- Cleaning upholstery 59
- Cleaning windows, closed cars 27
- Clock 27
- Clock, repairs to 112
- CLUTCH AND TRANSMISSION 97
- Clutch, construction of 97
- Clutch pedal 16
- Clutch release rod, adjustment of 97
- Clutch thrust bearing, to grease 55
- Coasting 22
- COLD WEATHER OPERATION 38
- Contents 5
- Contact points, adjustment of 89
- CONTROLS AND INSTRUMENTS 9
- Control, spark lever 11
- Control, throttle lever 10
- Control, transmission 17
- COOLING SYSTEM 79
- Cooling system, capacity 39
- Cooling system, drain and refill 80
- Cooling system, to clean 81
- Cowl ventilators, open cars 27
- Crankcase ventilating system 50
- Curtain fasteners, open cars 29
- Curtains, side, open cars 27
- Cylinder heads 69
- D**
- Danger of running engine in closed garage 21
- Data for license purposes 113
- Diagram, chassis lubrication 54
- Disc wheels, to change 37
- Distributor oil cup, fill with oil 52
- Don't's for general operation 23
- Door hardware, to oil 57
- Draining cooling system 80
- DRIVING 21
- Driving on steep grades 22
- Driving speed when car is new 21
- Driving suggestions 23
- Duco finished cars, to wash 59
- E**
- Effect of alcohol on finish of body 39
- ELECTRICAL SYSTEM 83
- ENGINE 68
- Engine fails to start 14
- Engine, important features of 68
- ENGINE LUBRICATION 48
- Engine number, location of 113
- Engine oil 46
- Engine oil, to replace 51
- Engine, prepare for storage 64

Engine, starting of	13	Lever, spark control	11
Engine, starting in cold weather	41	Lever, throttle control	10
EQUIPMENT	26	Lever, transmission control	17
Equipment, tools	30	License data	113
Exide depots for battery maintenance	87	Lighter, cigar	27
		Lighting switch	20
		Lighting system	93
F		Locks	9
Fan belt adjustment	79	Lubricant for chassis	47
Fasteners, curtain, open cars	29	Lubricants	46
Fiber grease	47	LUBRICATION AND CARE	43
Filling and draining cooling system	80	Lubrication chart	54
Filter for gasoline	75	LUBRICATION, ENGINE	48
Filter for oil	50	Lubrication schedule	44
Finish of body, care of, when new	58	Lubrication, systematic	45
Foot brakes	19		
Foreword	3	M	
FRONT AXLE	103	Mirror, rear vision	27
Front wheels, alignment of	103		
		N	
G		New car, driving speed	21
Gas in closed garage, when engine is running	25	New car, washing	58
Gasoline filter	71		
Gasoline gauge	10	O	
Gasoline strainer, cleaning in cold weather	40	Official approval of headlamps	93
GASOLINE SYSTEM	73	Oil circulating system	48
Gauge, gasoline quantity	10	Oil cups on generator, to fill	52
Gauge, oil pressure	15	Oil cup on timer-distributor	52
General driving suggestions	24	Oil filter	50
GENERAL INFORMATION	67	Oil for engine	46
GENERAL LUBRICATION	55	Oil for engine in cold weather	40
General operation don'ts	24	Oil level	49
Generator	83	Oil pressure	15
Generator oil cups, fill with oil	52	Oil pressure regulator	50
Genuine La Salle parts	111	Oil replacing of, in engine	51
Grease gun connections, to grease	55	Operation, in cold weather	38
Grinding valves	70	Operation don'ts	23
		Operation of starter	87
		Ordering new parts	111
H		P	
Hand brakes	19	Parts, genuine La Salle	111
Hardware on doors, to oil	57	Parts, ordering new	111
Headlamp reflectors, to clean	93	Parts, returning of	112
Headlamps, adjustment of	93	Pedal, clutch	16
Headlamps, operation use of beams	20	Pedal, foot brake	19
		Pedal, starter	13
		Position of spark control lever	11, 42
I		Position of throttle hand lever	10, 42
Ignition, general description of	88	Pressure for tires	32
Ignition spark control lever	11	Pressure of oil	49
Ignition switch	9	Pressure, oil gauge	15
Ignition timing	90	Prices of parts, uniform	111
Inflation pressure, tires	32	Priming the carburetor in cold weather	41
Inflation of tires, under-inflation	61		
INSTRUMENTS AND CONTROLS	9	R	
		Radiator and shutters	79
L		Rear axle, to add lubricant	56
Lamp bulbs	93	REAR AXLE AND TORSION	
Level for oil, engine	49	TUBE	106

Rear vision mirror	27	Timer-distributor	88
REPAIR PARTS	111	Timer-distributor oil cup, fill with oil	52
Repairs to speedometer head	119	Timing ignition	89
Replacing engine oil	51	Tire balancing marks	106
Result of under-inflation of tires	61	Tire carrier, (tire holder)	32
Returning parts	112	Tire chains, improperly adjusted	61
Rim, true up	34	Tire holder	32
		Tire pressure	32
		Tires	30
S		Tires, care of	61
Schedule of lubrication	44	Tires, to change	34
Shifting transmission gears	17	Tire valve caps	32
Shutters on radiator	79	Tools	30
Side curtains, open cars	29	Tools (illustration)	31
Small cuts in tires, neglect of	61	Top, care of when car is stored	105
Solutions for anti-freeze	38	Torsion tube	66
Spark control lever	11	Transmission control	17
Spark plugs	91	Transmission, to add lubricant	55
Specific gravity of battery solution	86	Truing up rim	34
SPECIFICATIONS AND LICENSE			
DATA	113	U	
Speed of new car	21	Uniform parts prices	111
Speedometer	19	Upholstery, to clean	59
Speedometer flexible drive shaft, to lubricate	56	Use of accelerator before engine is warm	42
Speedometer lubrication notice	46	Use of jack in changing tires	34
Speedometer, repairs to	112	Use of starter in cold weather	42
Springs, to lubricate leaves	56		
Starter pedal	13	V	
Starter, use of in cold weather	42	Vacuum tank	74
Starting engine	13	Valve caps, tire	32
Starting engine in cold weather	41	Valve grinding	70
Starting motor	87	Valve stem clearance	69
Steering connecting rod	102	Valve stems, how lubricated	49
STEERING GEAR	100	Varnished cars, washing, when new	58
Steering gear, add lubricant	50	Ventilating system for crankcase	50
Strainer in gasoline system	40, 75	Ventilators in cowl, open cars	27
Storage battery	85		
Storage battery, location on car	85	W	
Storage battery, when car is stored	64	Washing Duco finished cars	59
Storage of car, placing car in service	65	Washing varnished cars	58
Storage of tires	65	Water circulation	79
STORING CAR	64	Water pump	80
Suggestions for driving	23	Water pump, lubrication of	52
Switch, ignition	9	Wheel alignment	103
Switch, lighting	20	WHEELS	106
SYSTEMATIC LUBRICATION	45	Wheels, pack bearings with grease	56
		Wheels, removal of	106
		Wheels, to adjust bearings of	107
T		Windows, to clean	59
Taking car out of storage	65	Windshield and ventilation	26
Throttle control	10	Windshield cleaner	27
Throttle hand lever position, cold weather	42	Wire wheels, to change	36



This document was downloaded free from

www.iw1axr.eu/carmanual.htm

Questo documento è stato scaricato gratuitamente da

www.iw1axr.eu/auto.htm