

CRYSTAL SETS TO SIDEBAND

© Frank W. Harris 2006, REV 10

Chapter 10

Variable Frequency Oscillators (VFOs)

Sooner or later you'll become frustrated with being stuck on a few crystal-controlled frequencies. You would like to have a frequency-tuning knob that covers the entire band and not just a few kilohertz. This sounds simple, but isn't. It's hard because, without the stability of a crystal, an ordinary RF oscillator will drift hundreds of hertz while you're sending. The fellow you're talking to probably has a modern transceiver with a narrow, stable passband. From his perspective your signal quickly drifts out of his passband. His digital readout may be calibrated to tenths of a Hertz and he will take great delight in telling you about *YOUR PROBLEM*.

Drift is a big deal today

In the old days, like 1950, receiver passbands were usually huge, like 10 or 20 kilohertz. So you could drift quite a distance before your contact even noticed, let alone could no longer hear you. Besides, everyone drifted a little back then, so it wasn't worth mentioning. In the really old days, like 1930, the signals drifted so much, that hams often tuned their receivers with one hand while they copied down the Morse code with the other.

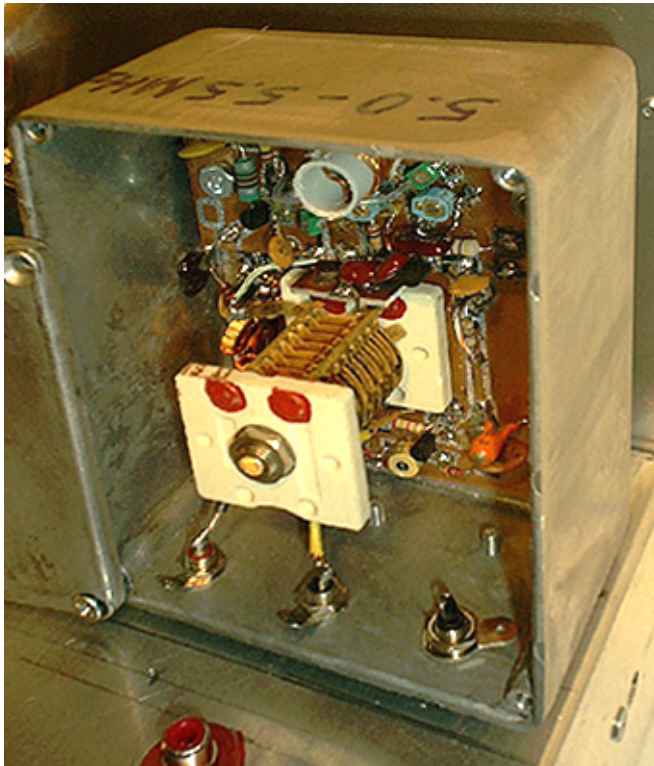

A 5 MHz VFO tuned by a mechanical variable capacitor

A stable variable frequency oscillator can replace a crystal oscillator. This chapter summarizes what I learned in my odyssey through six VFO prototypes. My early VFOs drifted hundreds of Hz and I got loads of complaints. After I added temperature compensation, I got the instability down to 20 Hz drift per minute. Some stations notice 20 Hz drift and a few even told me about it. Eventually I built a super-regulated power supply for the VFO and got the drift down to about 5 Hz. I suggest you avoid embarrassment and work directly toward 5 Hz. According to the ARRL handbook, +/- 5 Hz is about as good as you can do without phase lock loop technology.

2. Chapter 10, Harris

I was recently talking to a brand new local ham on 40 meters CW. We were chatting at a leisurely 5 words per minute. He, of course, was using a wondrous modern transceiver. It took us an hour to communicate very little information. Finally he tired of the strain and called me on the phone. "By the way," he said, "were you aware that you drifted over 50 Hz during our QSO?" He thought he was informing me of a grievous defect in my rig. I was delighted that the drift was so low.

The test equipment needed to build a VFO are a precision multimeter for measuring voltage down to millivolts and a frequency standard. A super-accurate, modern receiver is OK, but a frequency counter is better for this application. The hardest part about building a stable VFO is following all the detailed instructions on how to do it. If you're like me, you'll have trouble believing that all that trivia is really necessary. Yes, you can cut a few corners, but the more compromises you make, the more your VFO will drift.

Low frequency VFOs drift less than high frequency VFOs

For HF transmitters running on 160 meters (1.8 to 2.0 MHz) or on 80 meters (3.5 to 4.0 MHz), it's practical to build a VFO that operates directly on those frequencies. For those bands you may amplify the VFO signal directly. For example, if you had a crystal-controlled QRP designed for 80 meters, an 80 meter VFO could be plugged directly into the crystal socket. You might want to attenuate the signal somewhat before directly substituting a crystal, but the VFO can replace the crystal and allow you to tune all over the band. If you can build a really first rate VFO for 40 meters, that band would also be practical. Unfortunately, for a given level of sophistication and precision, frequency drift is directly proportional to frequency. You will probably find that somewhere above 5 MHz, there is too much instability to keep the drift under 5 Hz per minute. In order to build a low drift VFO for 40 meters or above, a low frequency VFO can be "converted" up to the desired high frequency. Conversion means adding the VFO to a high frequency crystal oscillator signal and then extracting the sum frequency with a filter. Frequency conversion is covered in chapter 11.

Considering the size of most HF ham bands, a VFO needs a tuning range of at least 0.5 MHz. The higher the basic frequency of the VFO, the wider the tuning range you can achieve. ARRL handbook VFO projects have various frequencies ranging from 1.75 to 9 MHz. My CW transmitter VFO ranges from 3.5 to 4.0 MHz. My receiver and SSB-transmitter VFOs tune from 5.0 to 5.5 MHz. In retrospect, if I were starting over, I would have built the 5 MHz VFO first, since that frequency turns out to be more versatile. The disadvantage of a 5 MHz VFO is that it can't be used on any hamband directly and every hamband needs a frequency converter circuit. (Yes, a 5 MHz VFO can reach 60 meters. But CW isn't permitted on 60 and generating SSB on the same frequency on which you're transmitting requires a phase shift technique that is rarely used today.)

JFET transistors

Junction Field Effect Transistors (JFETs) are ideal for building VFOs. Unlike bipolar transistors, the main current from the drain to the source does not pass through any PN junctions. PN junctions change their characteristics with temperature. Therefore, VFOs made from bipolar transistors tend to drift more than JFETs. JFETs work on the same principle as a MOSFET, but the control gate is a P-N junction diode rather than a capacitor. JFETs were explained and used in the VFO oscillator in the direct conversion receiver in chapter 7.

THE VFO CIRCUIT

The basic oscillator

In principle the VFO is almost the same as a quartz crystal oscillator. The crystal is electrically equivalent to an LC resonant circuit. Therefore, to tune a VFO we use either a variable capacitor or a variable inductor to change the resonant frequency. So far as I know, suitable variable inductors can't be bought or built in a basement. That means that the tuning element will have to be a variable capacitor, much like the one you used to adjust the crystal frequency in your QRP.

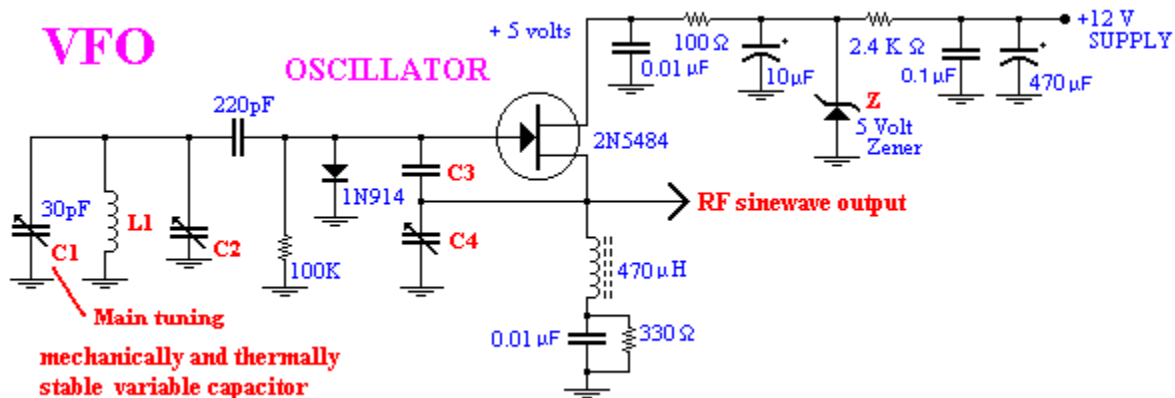

The circuit above is essentially what you will find in your ARRL handbook. It uses a JFET transistor. The oscillator is a *Colpitts* and can be recognized by the capacitive divider feedback, C3 and C4. Whenever the source voltage goes up, some of this change is coupled to the gate through C3. This turns the JFET more ON. That is, the feedback is positive which sustains the oscillation. The basic LC resonant circuit that determines the frequency is C1 and L1. C2 is a trimmer capacitor to help adjust the desired tuning range.

So what are the values of C1, L1, C2, etc.? The answer isn't simple. We start with a quality variable capacitor for C1 as described below. For various reasons, **C1 will probably be about 30 pF**. Starting with this capacitor and the need for a 0.5 MHz tuning range, the other values must be determined by trial and error. The values are extremely hard to calculate because C3, C4 and even the 1N914 diode are part of the capacitance. Don't try too hard to get the values right until you have studied this entire chapter and formulated a plan for your VFO. As you will see later, C2, C3, and C4 are part of the temperature compensation strategy and will need to be determined by those considerations first. When you have decided what to do about C3 and C4, then you can work on L1 and C2.

The 1N914 diode on the gate seems counter-productive, but it is used as a clamp to keep the base of the JFET transistor out of the forward conduction region. That is, when the oscillation gets too vigorous and the gate P-N junction begins to turn on at 0.6 volts, the diode will help prevent operation in this range. The VFO as a whole is powered by 12 volts. However, 5 volts derived from a Zener diode regulator (Z) power the oscillator stage and its buffer. This is done to dissipate as little energy as possible in the oscillator and prevent the components from heating.

The entire VFO circuit

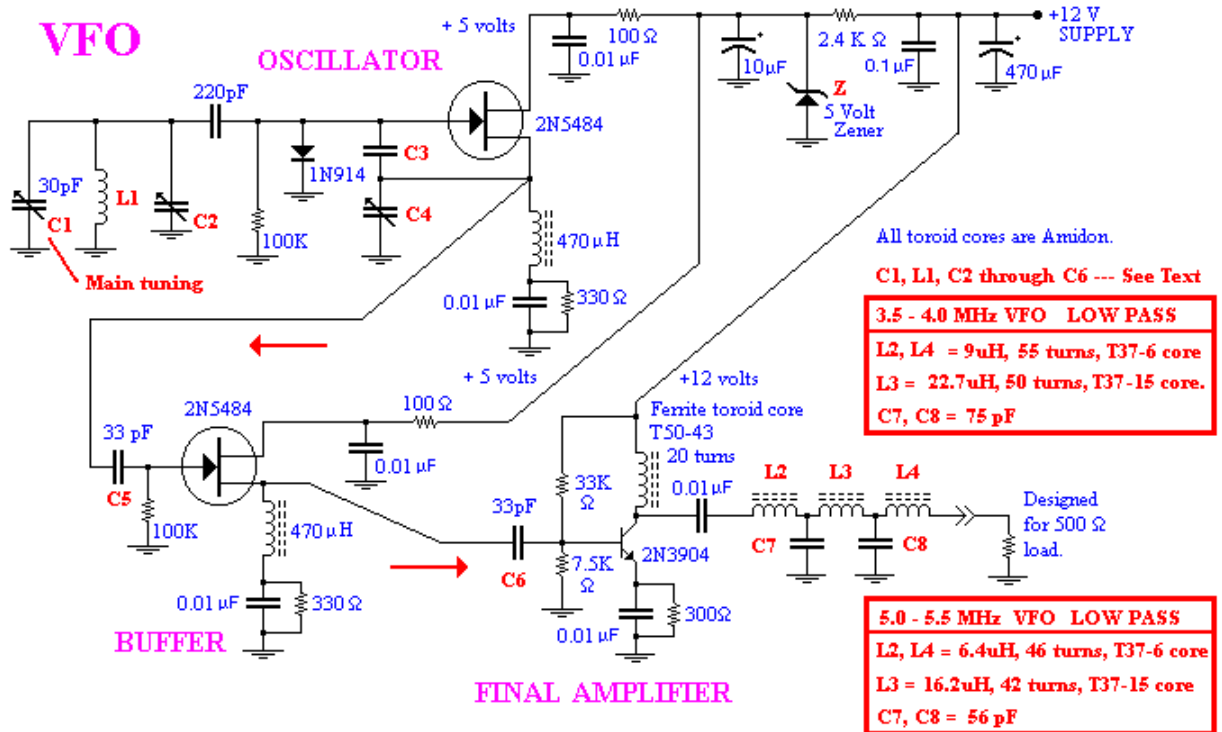

Here is the entire VFO circuit, excluding the temperature compensation. As you can see, the VFO also contains a buffer stage and a final amplifier. Temperature compensation consists of special circuits that replace either C2 or C4.

Buffer

The buffer stage separates the oscillator from the final amplifier. Otherwise there would be a subtle connection between the load on the VFO output and the oscillator. Believe it or not, without the buffer, if you change the load on the VFO output slightly, the frequency will change too. The buffer is connected to the other stages by C5 and C6. These capacitors should be as small as possible to reduce the connection between the oscillator and final amplifier.

Final amplifier

The final amplifier raises the VFO output up to the level needed to drive the transmitter. The stage being driven in the transmitter is usually a “mixer” which we shall discuss in the next chapter. But, if the VFO is designed for the 80 meter ham band, then the next stage after the VFO could be a string of class C amplifiers to increase the output power to the final level, say 5 or 50 watts. The VFO final stage will need to deliver at least two volts peak sine wave. Since we have deliberately kept the oscillator and buffer signals tiny, the final amplifier must be a linear or Class A amplifier to get the signal level up to 2 to 5 volts peak. The drive to this transistor is biased with a 33K resistor so that this stage is always turned on.

Low pass filter

The drive to the transmitter should be as pure a sinewave as possible avoid radiating

harmonics outside the hamband. A low pass filter on the output attenuates most of the harmonics above the desired frequency range. A Chebyshev low pass filter is shown designed for a 500 ohm load. In Chapter 6 you were introduced to Chebyshev filters designed for 50 ohms. However, here we have no need for power, just voltage. Therefore, the filter is designed for 500 ohms, which is plenty of drive current for this application. Values are given for both a 80 meter VFO (3.5 to 4.0 MHz) or a 5 MHz VFO (5.0 to 5.5 MHz).

The 50 secrets of avoiding drift

Suppose you were to build the above VFO without reading the details in the following paragraphs: When you first turn it on, you will be disappointed to find that it drifts a hundred Hz per minute or more. *The drift is caused by temperature change.* The components expand and contract with temperature and this causes small changes in the capacitance and inductance of the components. Air wafting across the board doesn't allow the temperature to stabilize. *Drift is prevented by preventing temperature change and by choosing components that change as little as possible with temperature.*

VFO building is an art form as arcane as Grandma's secret piecrust recipe or the fine points of building Cub Scout Pinewood Derby racers. As you'll see, there must be 50 ways to improve the drift problem. I have never built a VFO that was completely "stable" and probably never will. But perhaps that's because I only know the 14 secrets listed below. If you apply as many of these as possible, you should get within the 20 Hz target - and maybe even under 5 Hz.

Secret # 1. Use Junction Field Effect Transistors (JFETs). The first secret of a stable VFO is using a JFET instead of a bipolar transistor. As described earlier, a field effect transistor is better because it is less sensitive to temperature. I have used 2N3823, 2N5484, and 2N4416 N-channel JFET's for VFO oscillators. My impression is that any small N-channel FET works well.

Secret # 2. Seal the VFO in a cast metal box. Simply protecting the VFO from air currents makes a huge improvement. Use a heavy cast metal box so that the temperature will at least change slowly. In contrast, a flimsy sheet-metal aluminum box will heat and cool relatively rapidly. On the other hand, *ANY* box is a huge improvement over not having the circuit sealed from air currents.

Secret # 3. Use single-sided PC board. A double-sided PC board is constructed like a capacitor. That is, thin metal sheets are bonded to a layer of insulator. Unfortunately, the resulting capacitor has a significant temperature coefficient. As temperature increases, the board material expands (thickens) and the capacitance across the board drops. If the VFO is built on traces and islands that have changing capacitance to ground, the frequency of the oscillator will drift slightly.

Secret #4. Mount the oscillator PC board away from the metal case on standoffs. Following the same principle as above, do not mount the single-sided PC board flush against the metal case. By standing the board up and away from the case, the capacitance between the traces and the metal case can be minimized.

Secret #5. Choose and mount all components affecting the oscillator LC circuit carefully. All the L and C components in the oscillator should be designed for minimum temperature drift.

6. Chapter 10, Harris

Referring to the diagram, it is not just capacitors C1 and C2 that affect the frequency. Capacitors in series with the 220 pF capacitor, C3, C4, and even C5 affect the frequency. To at least a tiny degree, ALL components in contact with these capacitances can affect frequency drift. These include the diode, the RF choke, the transistor, and the 100 K resistor.

Secret # 6. Mechanical variable capacitors should be chosen carefully. Although good mechanical variable capacitors are hard to find, they may be the best solution for you. Pick a capacitor of about 30 to 60 pF, not larger. High capacitance variable capacitors are too sensitive to temperature change. Smaller ones don't tune far enough. *Don't use a capacitor with aluminum plates* – they warp too much with temperature. *Brass is the best metal. Try to find a capacitor with thick, widely-spaced plates.* Paper-thin plates are compact, but warp readily with temperature change.

An assortment of variable caps is shown below. The big brass variable cap just to the right of center is rather big physically. However, out of this group it is the best for a VFO. The capacitor to its right is quite stable, but its capacitance is too small. The tiny green plastic caps in the clear plastic strip are positive temperature coefficient variables useful for VFO temperature compensation. The round ceramic white and silver trimmer just above them is my favorite 60 pF trimmer. I used dozens of them in the projects of this book. The small variable cap at the bottom center has surprisingly large capacitance, 250 pF. Unfortunately it's too unstable for a VFO.

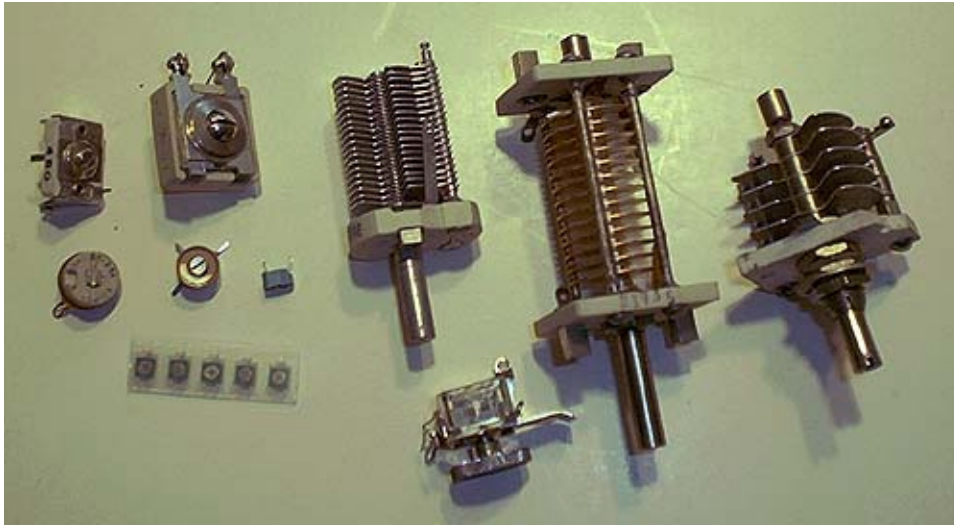

If the capacitor tuning is linear with degrees of rotation, the frequency it produces will be somewhat non-linear. Ideally, the capacitor plates should have a non-linear shape that allows it to tune an LC resonant circuit so that the frequency will be linear. Rotate the capacitor through its range and you'll see that a compensated capacitor has rotor plates that are not simple half circles. As they rotate, they do not mesh with the stator plates at the same point. The non-linear correction isn't a big deal, but it is something to be aware of. RF Parts Co. sometimes has adequate capacitors in stock. See www.rfparts.com.

Secret # 7. Varactors are the most stable tuning element. It's hard to buy mechanical variable capacitors that are mechanically and thermally stable. Collins Radio formerly tuned their VFOs with special powdered-iron slug-tuned coils, but I've never seen any for sale. A varactor capacitor controlled by a quality pot is a good solution to these problems. Varactors are

a kind of silicon diode biased with DC voltage. In my experience varactors are an order of magnitude more thermally stable than mechanical capacitors. They are at least two orders of magnitude more mechanically stable. You can slap the VFO with your hand and, although other components may vibrate, the varactor will not change its capacitance.

Unfortunately, varactors produce a non-linear scale on the frequency tuning knob. This means that the high frequency end of the VFO range will be extremely detailed while the low end may be compressed into a few degrees of rotation. For this to be usable, the potentiometer should be non-linear to compensate. Varactors are discussed in detail below.

Secret # 8. Use NPO fixed capacitors. When selecting fixed capacitors, look for type NPO. These are supposed to have minimum temperature change. Use these for *ALL* fixed capacitors affecting the LC circuit.

Secret # 9. Use multiple NPO capacitors in parallel to achieve a given value. If you must use fixed capacitors in parallel with C1 or C2, it is better to use several small ones in parallel than one large capacitor. The temperature of a small capacitor stabilizes quickly, whereas heat builds up more slowly in a larger capacitor.

Secret # 10. Temperature compensation for the LC circuit is essential. It took me four prototypes to accept this, but temperature compensation is as important as putting the VFO in a box. Lots of guys claim to have succeeded without it, but I never have. Not using temperature compensation implies that every capacitor and inductance in the VFO must have a zero temperature coefficient. Alternatively, all negative coefficients must be balanced precisely with components that have positive temperature coefficients. Good luck doing that! Compensation circuits are described below.

Secret # 11. Use an air core inductor. As usual, it is most convenient to use a powdered iron toroid core. Unfortunately, powdered iron changes its permeability (magnetism factor) with temperature. Therefore, by not using iron, another variable is eliminated. I have successfully used old plastic pen caps as little coil forms for air-core inductors. I bore little holes in the plastic to accept tiny pieces of stiff copper wires to serve as wiring terminals.

If you do use powdered iron, among the CWS (Amidon) cores, type #7 is supposed to have the best thermal stability. CWS Bytemark (Amidon) #6 cores have worked reasonably well for me but maybe #7 would be a few percent better. If you make a coil out of turns of copper wire on a plastic form, the copper will change its dimensions slightly with temperature too. And because an air core inductor requires more turns of wire, there is more opportunity for the copper to change its dimensions, its interwinding capacitance, and also its resistance. Finally, an air-core coil will couple like a transformer to nearby parts whereas a powdered iron toroid couples far less. Sigh. Nothing is perfect.

After you have your coil wound and working over the right frequency range, epoxy or clamp it to the board. Without the epoxy, the frequency will warble with the slightest vibration. I once tried to use slug-tuned coils. They were convenient to adjust, but were mechanically and thermally unstable.

Secret # 12. Precision voltage regulation for the VFO supply is vital for precision frequency stability. The 12 volt supply for the VFO as whole must be regulated. Ordinary voltage regulators like the LM317 or LM7812 gave me regulation within 0.1 volt. This was OK

for frequency stability down to about 20 Hz drift. But to get down to less than 5 Hz, I needed to regulate my VFO power supply to a few millivolts. To achieve this, I built a precision supply that just powers the VFO. The less current the supply has to deliver, the more constant its output voltage will be. The supply is discussed in detail below.

Secret # 13. The VFO should draw as little power as possible. The less power drawn, the less heating that occurs inside the VFO box. Also, the less power drawn, the easier it is to build a precision voltage supply to drive the VFO. That is why the VFO was designed for a 500 ohm load rather than 50 ohms like most ham RF circuits. The VFO as a whole should draw less 20 mA DC. 10 mA would be even better.

My next attempt at a VFO will house the oscillator and buffer inside the cast metal box and put the "high power" final stage outside the box so its heat can't affect the oscillator. Another idea I'm going to try is to run the oscillator on even less voltage, perhaps 1.5 to 3 volts.

Secret # 14. Forget tube oscillators. You old timers may be tempted to use a tube oscillator. I first tried to update an old tube VFO, but tubes get hot and make temperature compensation too difficult. You'll have plenty of trouble without this extra burden. You may use bipolar transistors for the final amplifier in your VFO, but not for the oscillator. For good measure you may as well use a JFET for the buffer as well.

.....

Vernier mechanical tuning and frequency indicator

Because a VFO must be tuned precisely to the other fellow's frequency, it is vital to use a vernier tuning gear between the tuning knob and the variable capacitor. In my opinion, the tuning knob should rotate at least three times around for each revolution of the capacitor. Without vernier tuning, it will be exceedingly difficult to tune your receiver or transmitter accurately to the other fellow's frequency. A planetary reduction gear is generally mounted on the front panel. Machine screws clamp it to the ¼ inch capacitor tuning shaft that protrudes from the VFO box. Tuning gear systems are usually combined with a dial and pointer that you can calibrate. A paper dial can be marked with ink for the calibrations. A plastic cover protects the paper from moisture.



I used a National Company brand vernier dial on one of my VFOs shown at left. Recent interest in QRPs has made these available again after being absent for some years. Look for the ads in ham magazines. Unfortunately, these dials are pretty pricey. For some of my VFOs I used a military surplus reduction gear that had no pointer and dial. I made the pointer out of super-thin PC board painted black. The dial calibrations were on thin white cardboard covered with 1/8 inch Lucite plastic and screwed onto the front panel.

If you use a varactor variable capacitor as described below, you may be able to find a multi-turn potentiometer for your tuning vernier. This solves the vernier problem, but doesn't offer a way to calibrate the dial. Some hams have built elaborate frequency counters or digital voltmeters as solutions for VFO calibration. All I can say is beware of digital circuitry in your ham equipment. Homebuilt digital circuits nearly always generate radio noise that will interfere with hearing weak signals. Commercial manufacturers make digital technology look easy. But so far, all my digital toys have generated a static "hiss" that I have regretted.

Varactor Tuning

While building a new receiver, I had to construct another VFO. In this prototype I explored replacing the mechanical tuning capacitor with a varactor. Back-biased P-N junctions block the flow of charge as if they were capacitors. They not only act like capacitors, when back-biased, *they are capacitors*. The interesting aspect of this behavior is that, by biasing them with a DC voltage, say 0 to 10 volts, the capacitance can be tuned like a variable capacitor. As more and more voltage is placed across the diode, the ions in the semiconductor are used up and the charge it can store is diminished. In other words, PN junction diodes change their capacitance inversely proportional to the voltage on them. *Varactors are voltage-variable capacitors.*

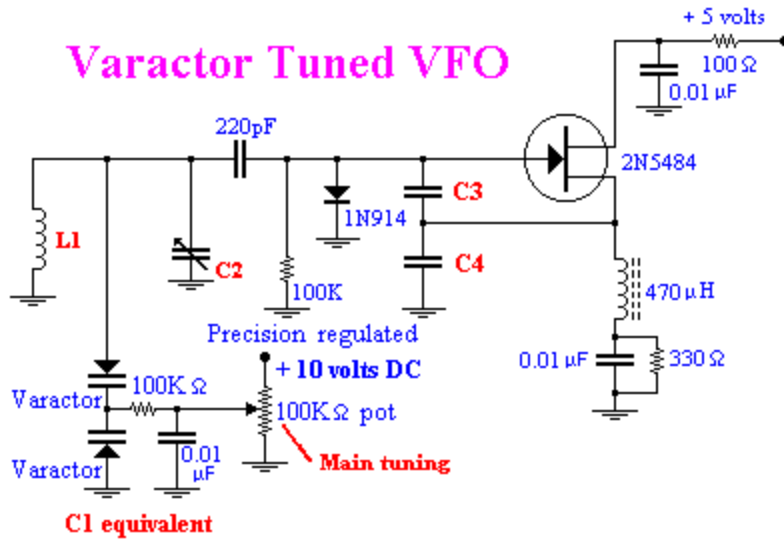

A VFO tuned by varactor. The round potentiometer adjusts the voltage on the varactor.

Since then I bought a varactor, Motorola type MV104, that has a capacitance of 110 pF. (!!!) This device has the potential to provide the large tuning range needed for covering the 10 meter band. Alternatively, it can be operated over a narrow range of bias voltage and thereby largely solve the non-linearity problem.

The advantages of varactor tuning are:

1. **Varactors are mechanically stable.** Assuming the potentiometer driving your varactor is mechanically stable, then the resulting VFO will be mechanically stable. You can bang the table with your fist and the frequency will barely warble in the receiver.
2. **Varactors are more thermally stable than mechanical capacitors.** When testing a mechanical capacitor VFO circuit with a hair dryer, I found that the blast of hot air on the circuit

Varactors are specialized P-N junction silicon diodes that were designed just for this purpose. However, I have seen VFO circuits that use ordinary silicon diodes like the 1N914 or 1N4148 as varactors. One of the disadvantages of most varactors is that they usually don't have much capacitance. 5 to 20 pF is typical. Because of this, I didn't believe I could get enough tuning range from a varactor. It turned out that I could compensate by using two or more varactors in parallel and by decreasing the size of the feedback capacitors C3 and C4. Tuning range wasn't a problem.

board caused the frequency to soar or plunge hundreds of Hz, sometimes even KHz. When my varactor VFO is given the same treatment, the frequency change is an order of magnitude less.

3. Varactors are available. Good mechanical tuning capacitors are hard to find. In contrast, varactors can always be purchased from Digi-Key, Mouser, and other companies.

4. Varactors are tiny. Some of the ones I used are the size of a grain of sand. Soldering them on my circuit board required patience, sharp tweezers, and a jeweler's loupe. A VFO module made with a varactor can be much smaller than a VFO made with a mechanical variable capacitor. Also, the varactor can be tuned by a potentiometer located at some distance away on a front panel.

5. Varactor VFOs may be tuned by phase-lock loops. Since the varactor VFO is tuned by a variable DC voltage, it can be part of a modern phase-lock loop design. A homebrew VFO doesn't have to be confined to old technology.

The problem with varactors

Alas, varactor-tuned VFOs are non-linear. However, you can turn this to your advantage. As the DC voltage is changed across the varactor, the frequency change it produces is not linear. When the voltage is first applied, the holes and electrons in the PN junction are filled in readily and decrease the capacitance rapidly. After the first big change, more and more voltage must be applied to fill in more holes and deplete the electrons in the N-type semiconductor. In other words, the wider the tuning range, the more non-linear the relationship between applied voltage and frequency. This exaggerates the tuning of the high-end frequency end of the band. For example, if the varactor is pushed to its maximum capacitance range, then 75% of the voltage tuning range might be needed to cover the upper 25% of your total frequency range.

Suppose you are primarily interested in CW operation. The CW portion of the band is always at the bottom of the hamband with phone at the high frequency end. The linearity problem can become an advantage by designing the VFO frequency converter in your transmitter or receiver so that, for each band, the high frequency end of the VFO range covers the low CW end of the ham band. CW signals have little bandwidth, a few Hz, and the CW bands are often crowded. In contrast, although phone bands are sometimes crowded, the phone bands are several times wider and the phone signals themselves each cover 3 KHz. In other words, good bandspread, (small frequency change for big knob rotation), is important for the CW band and not so important for the phone band. Yes, tuning in SSB phone requires fine-tuning. But you may find that tweaking the speech quality is more easily done with the receiver BFO knob than with the VFO tuning.

For example, in a transmitter, the VFO might range from 5.0 to 5.5 MHz. To transmit on 40 meters (7.00 to 7.30 MHz), the transmitter could use a 12.5 MHz crystal controlled local oscillator to cover from 7.0 to 7.5 MHz. That is, $12.5 \text{ MHz} - 5.5 \text{ MHz} = 7.0 \text{ MHz}$. In this way, the high end of the VFO tuning covers the *LOW* end of the ham band. In contrast, if you use a low frequency crystal, 2.0 MHz (e.g., $2.0 \text{ MHz} + 5.3 \text{ MHz} = 7.300 \text{ MHz}$), the high frequency end of the VFO will cover the upper end of the phone band where bandspread isn't very important. If you're confused, frequency converters are explained in detail in chapter 11.

Frequency offset on transmit

A transmitter VFO has a problem you may not have thought about. With an old-fashioned, wideband CW receiver, when you tune past a CW signal, you'll hear a whistle that changes from a high pitch to a low pitch or "zero beat," then rises back up to a high pitch as you continue to change frequency. If your receiver were tuned precisely to the other guy's frequency, he would be at the "zero beat." His CW signal would have such a low pitch you wouldn't be able to hear it.

To fix this, modern transceivers automatically add a frequency offset between receive and transmit, usually 700 or 800 Hz. Also, fancy transceivers don't receive the lower half of the signal unless the operator selects LSB on the front panel. In general, the lower sideband (LSB) is used on 160, 80, and 40 meters while the upper sideband, (USB) is used on 60 meters, 30 meters and above. With a modern, narrow bandwidth receiver, modern hams may not even be aware that there are two sidebands. The upshot is that, when you answer a CQ with your homebrew VFO, you must tune in the correct direction about 700 Hz above or below his zero beat point. Otherwise he won't even hear you. Old timers used to tune around, but modern guys don't. I believe I had this problem when I first got on the air with my homebrew rig. Few stations seemed to be able to hear me. Yet, when I did talk to someone, I got good signal reports.

The simplest solution is to use the narrow bandwidth filters on your receiver so that you can only hear the upper or lower sideband at one time. Then when you zero beat your signal on top of the fellow calling CQ, you only hear your VFO when you are on the correct sideband. Narrow passband filters for a homebrew receiver are discussed in chapter 13.

VFOs for transceivers

If you build a VFO for a transceiver, the VFO will be used during both receive and transmit. As explained above, it may be useful to add a varactor tuned offset adjustment to the VFO so that you can send and receive on slightly different frequencies. To do this, add an auxiliary low capacitance varactor adjustor in parallel with the main tuning. The technology is the same as was just described for varactor tuning, but the tuning range will be less than one KHz.

A precision power supply for the VFO

One of my VFOs had a relentless upward drift of 200 Hz per hour. I was puzzled until I noticed that my 12 volt VFO power supply had a subtle downward drift. Ordinary voltage regulators are crude compared to temperature compensated regulator ICs. Regulators like the LM317 or LM7812 drift hundredths of a volt per minute, especially if the load is more than 100 milliamperes. A simple Zener diode regulator can easily allow one or two tenths of a volt change on the oscillator. The solution is to build a precision voltage regulator. This 12 volt regulator should be located outside the VFO box. So far as possible, ***anything that generates heat should be kept outside the VFO box.***

Precision Zener diodes

The trick to building a precision, temperature-compensated power supply is a precision Zener diode reference. Ordinary Zeners vary their regulation voltage with temperature.

Precision Zeners are integrated circuits that behave like Zener diodes, but have temperature compensation circuitry and can be adjusted to exactly the rated voltage. The LM336–5.0 Zener diode can be adjusted with a trim pot to precisely 5.000 volts DC. It is designed to have the best temperature compensation at that exact voltage. Other than the pot and the diodes, this part is used like an ordinary Zener.

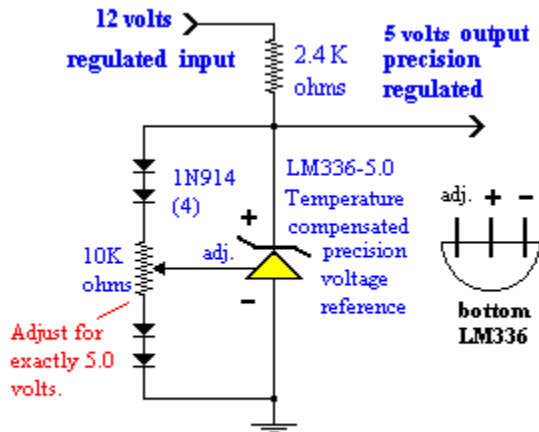

Precision 5 volt Zener

Yeah, I know. I promised I wouldn't use ICs that I couldn't build myself. I'm afraid precision regulators are beyond me. I've tried, but my attempts never exceeded the precision of the most ordinary IC voltage regulators. I did manage to build a pretty good voltage reference consisting of Zeners regulating other Zeners in a cascade in which some of the resistors were thermistors. Unfortunately, the final output was only stable at tiny voltages and tiny load currents and I couldn't successfully leverage it up to useful voltages and currents.

A precision 12 volt power supply

The precision voltage regulator shown below comes from the National Semiconductor Data Book for linear integrated circuits. This regulator will hold the VFO voltage constant to within about 2 millivolts. It uses a programmable LM317T regulator. (The "T" at the end identifies the TO-220 case style.) The output of the big regulator is "modified" with a precision Zener reference regulator to hold the output voltage constant. The LM317 regulates the voltage across the 1.2 K ohm resistor to about 1.2 volts. The precision reference then regulates the voltage across the 620 ohm resistor to exactly 6.2 volts - that is, 1.2 volts plus 5.000 volts. Since the voltage across the 620 ohm resistor is held constant, the current passing through the 1K potentiometer is also held constant. Therefore, adjusting the 1K pot can adjust the total voltage.

In order to maintain this high degree of precision, *the above regulator just powers the VFO*. When I tried to run other transmitter stages with the precision power supply, the load rose to several hundred milliamperes. Although the regulator chips were operating within specifications, the extra load ruined the millivolt precision regulation. I retrofitted my old capacitor-tuned VFO with the same precision regulator and found the frequency stability became as good as my newer varactor VFO.

I try to keep my VFO supply current down to less than 10 milliamperes. If you need more than a 3 volts peak output voltage, you'll probably find this difficult. In the full circuit shown above, by the time you get a 5 volts peak, pure sinewave, the current drawn from the supply is likely to approach 20 milliamperes. One way to compensate is to adjust the voltage from the precision supply to the bare minimum needed to provide the output waveform you need. That is, instead of using regulated 12 volts, use regulated 8 or 10 volts.

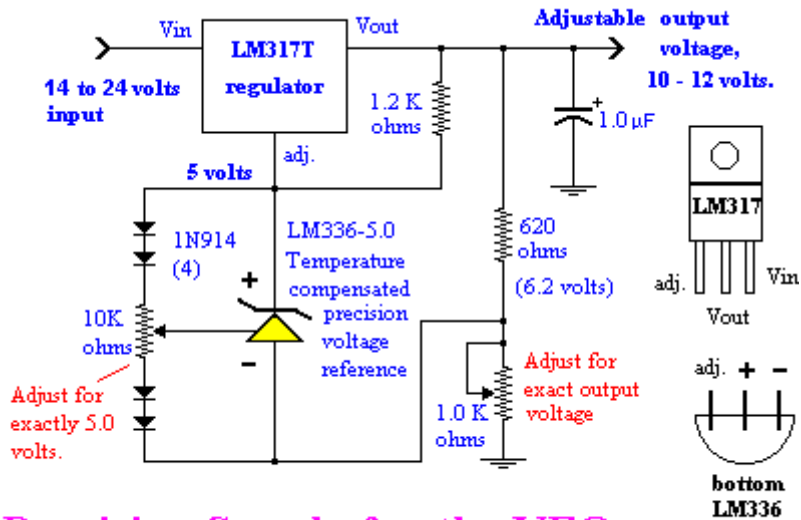

Precision Supply for the VFO

Separate regulation for the VFO oscillator

If your VFO is consuming more than about 10 mA, you may want to compensate for the temperature change inside the box by powering the oscillator inside the VFO box with 5 volts from a separate precision 5 volt Zener instead of using an ordinary 5 volt Zener.

A voltage doubler for battery use

If you're line powered, the regulator described above will probably work just fine, unless there is a brown out. On the other hand, if your transmitter is battery powered, its output voltage will fall well below 12 volts as the battery discharges. One solution is to run the VFO on regulated 9 volts. That way, even with 10 volts left on the battery, the regulator will still be providing 9.000 volts. However, if your VFO uses a varactor as the tuning element, you may need at least 10 volts to get the maximum tuning range from the varactor. My solution to this frustration was to first double the unregulated battery voltage. By starting with nominally two times the battery voltage, my VFO will always have at least 12 volts. Because the VFO only draws 10 to 20 mA DC, this DC voltage doubler does not have to be powerful.

A DC voltage doubler

Square wave generation

Any time you wish to raise a DC voltage, it is necessary to use the existing DC supply to generate a source of AC voltage. For example, the AC voltage could be applied to a transformer to produce as high an AC voltage as you need. The high AC voltage would then be rectified back into DC at the required high voltage. Instead of using a transformer, the voltage doubler described below uses a capacitive *charge pump* to raise the voltage. As you'll see, this technique is a specialized kind of rectification.

The first task is to convert the DC supply to square wave pulses. It turns out there are

many ways to generate square waves using integrated circuits. For example, I used an operational amplifier IC to generate the dots in the electronic bug in chapter 9. You may use an IC if you like, but you might enjoy doing it the hard way. As usual, if you're new to electronics, you'll learn some interesting concepts.

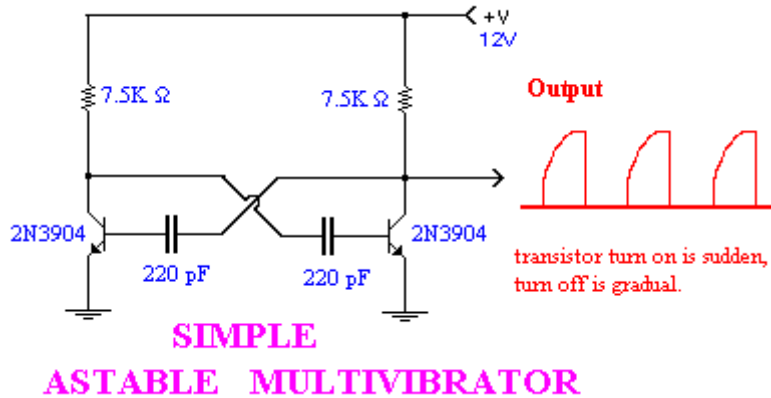

A simplified *astable multivibrator* oscillator is shown above. As you can see, this circuit consists of two grounded emitter amplifiers wired so that any change on the collector of one transistor is immediately coupled to the base of the other. Let's assume that the capacitor on the left is charged to a low voltage, say 1 volt. The capacitor on the right is charged to nearly 12 volts.

The capacitor on the left is charging toward 12 volts through the 7.5 K resistor on the right. As the positive charge flows out of the capacitor and into the base, the left transistor turns on. This pulls its collector and its respective capacitor toward ground.

Since the voltage across the capacitor on the right can't change instantly, the voltage on the right base is pushed downward to roughly -12 volts. This extreme negative voltage turns off the right hand transistor. The right hand capacitor with its -12 volts will discharge toward zero volts since there is now no source of voltage to maintain negative 12 volts. This discharge takes a significant length of time because the current must bleed into it through the 7.5 K ohm resistor. Eventually, the voltage on the right transistor's base rises above $+0.6$ volts, which will turn that transistor back on. When the right transistor turns on, it pushes the left hand capacitor back down to -12 volts turning off the left transistor.

A practical multivibrator

The simplified multivibrator described above oscillates OK, but it doesn't always start spontaneously. In fact, you will find that it only runs at a specific range of supply voltage and must be turned on abruptly. If you turn up the supply voltage gradually, the multivibrator remains stable with one or both sides turned off and the oscillation never begins.

The unreliability of the simple multivibrator can be fixed by biasing the transistors partly *ON* with the 100K ohm resistors. These resistors insure that the capacitors will always be charging or discharging. Now the circuit will generate square waves even with very low voltages. When the power supply voltage is turned up slowly, the oscillation will always start. Also, the *ON* state of each transistor is maintained longer and a better square wave results.

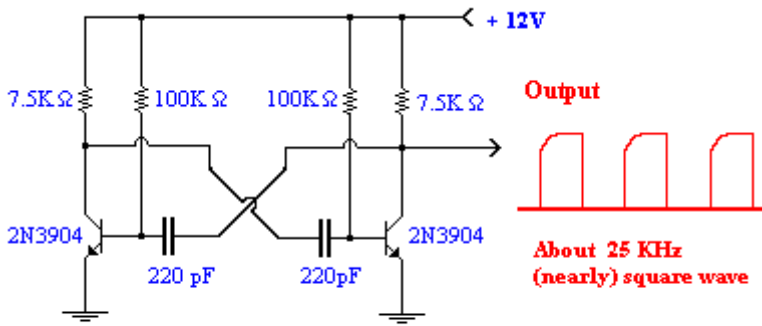

ASTABLE MULTIVIBRATOR

multivibrator. If a pulse is introduced to one transistor or the other, the circuit can be made to “flip-flop” to the opposite stable state in which the *OFF* transistor turns *ON* and the *ON* transistor turns *OFF*. The **flip-flop** circuit is the basis of static RAM memory (SRAM). One flip-flop can store one bit of information. So long as the supply voltage is applied, the circuit will “remember” one bit of information indefinitely. Or, it will remember it until another pulse comes along and resets it to the opposite state. In an integrated circuit SRAM literally millions of flip-flops are printed on a chip storing megabits of information.

Squaring up the low power square wave to drive a doubler charge pump

Now that we have a low-power, square-wave voltage, we need to clean up the waveform and amplify it so that we can produce about 30 mA squarewave AC for our VFO power supply. This is done with a simple buffer amplifier to make it square. A square waveform is important because the less time that the circuit spends “half turned on,” the more efficient the power supply will be.

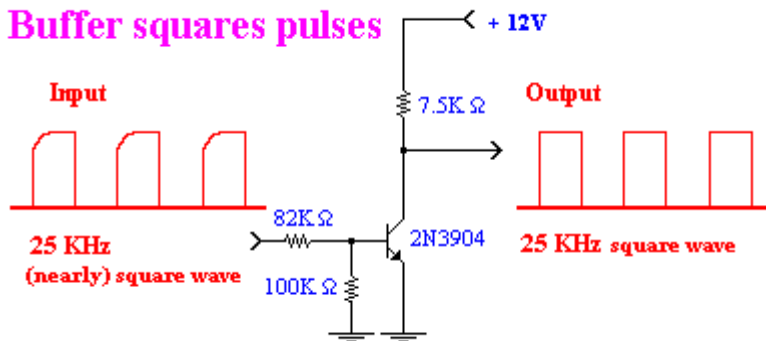

This square wave buffer is just a high gain voltage amplifier. During the sloping, rising input voltage, the upward slope of this voltage is exaggerated by 10 or 20 times. This diminishes the rise time until the rise time becomes negligible.

Diode voltage doubler

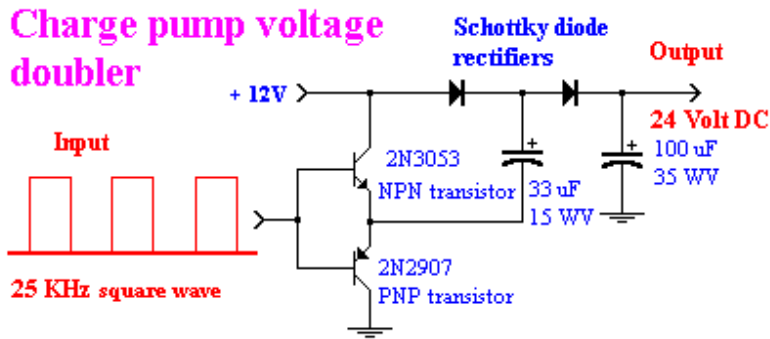

How can we “double” DC voltage using diodes? The idea is to repeatedly charge the $33\ \mu\text{F}$ capacitor to +12 volts as though that capacitor were a rechargeable battery. Then the capacitor is switched out of its “charging mode” and added like a battery on top of the existing

12 volt supply. In other words, 12 volts plus 12 more volts equals 24 volts. This pulsing, 24 volt signal then charges up the large $100\ \mu\text{F}$ storage capacitor on the right to 24 volts. Provided the current drawn from the 24 volts supply is small, the capacitor on the right can maintain a relatively constant voltage approaching 24 volts.

As shown above, the PNP and NPN transistors work together to pull the left hand capacitor up and push it down. When the PNP transistor is turned on, the bottom end of the capacitor is connected to ground. In this condition the diode on the left charges up the capacitor to 12 volts. When PNP turns off and the NPN turns on, the bottom end of the capacitor is suddenly shoved “up” and tied to the 12 volt supply line. Since the top of the capacitor is suddenly 12 volts higher than the supply line, the diode on the left is back-biased and can no longer charge it. Instead, the diode on the right is now forward biased and will discharge the 12 volts into the storage capacitor on the right. The capacitor on the right charges toward 24 volts thereby creating twice the original voltage.

Complementary transistors in action

In chapter four I mentioned that it was often convenient to have transistors that work with opposite polarities. As the drive to one transistor turns it on, the same polarity turns its complement transistor off. The output is taken off the emitters. In effect, the complementary transistors connect the output back and forth between ground and the 12 volt supply without any resistors becoming hot and wasting energy.

By the way, the logic circuits in your personal computer are almost entirely implemented with integrated circuits made from Complementary N-channel and P-channel MOSFET transistors. These ICs are called **CMOS**. By avoiding resistor loads on the FET drains, heating is minimized and switching speed is maximized.

Use Schottky rectifiers for best efficiency

Now we have loads of extra voltage, even when the battery supplying the transmitter is nearly exhausted, so there is still be plenty of voltage for the precision regulator to generate 12.000 volts. The supply works best if the two diodes in the voltage doubler are power Schottky diodes. These rectifier diodes only waste about 0.2 volts per diode when conducting current.

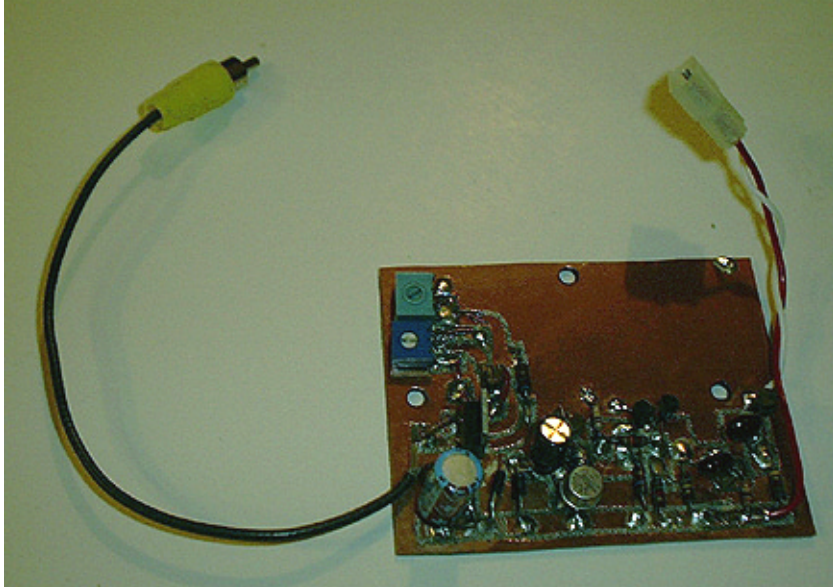

The down side of Schottky rectifiers is that they can usually only tolerate about 30 volts maximum, but that's plenty for this application. In the circuit shown on the left I used ordinary 1N4001 silicon rectifier diodes. Each of these wastes about 0.7 volts when turned on. Consequently, my 24 volt supply only delivers about 22 volts when the input is 12 volts.

VFO power supply board. It has a variable battery voltage input, precision regulated 12 volts output.

TEMPERATURE COMPENSATION

Supposedly, good VFOs can be built without temperature compensation. Personally, I've never succeeded, but don't let me be a wet blanket! Go ahead and try. Just leave room on the PC board to add compensation later.

The challenge is that most VFO parts such as variable capacitors, PC boards, etc. all have negative temperature coefficients. That is, their capacitance drops as temperature rises. The strategy of compensation is to substitute C2 or C4 with a capacitor that has an adjustable **positive temperature coefficient**. Therefore by paralleling the capacitance with a capacitor that has an equal but opposite positive temperature coefficient, the capacitance change will be cancelled. I suggest you start with this method of temperature compensation since it is the easiest.

Positive coefficient trimmer capacitive compensation

If you look in Digi-Key, Mouser, or other parts catalogs you'll occasionally find trimmer capacitors with positive temperature coefficients. These are capacitors that increase their capacitance with rising temperature. I used 20 to 40 pF variable trimmer capacitors made by Sprague-Goodman, type GCL. I replaced some of the fixed capacitance in the capacitive divider, C2 and C4, with two positive coefficient trimmers in parallel. ***The clever part is obtaining both the correct positive coefficient and the correct amount of positively changing capacitance. This is done by using a similar negative coefficient trimmer in parallel with the positive trimmer.*** By balancing the positive coefficient trimmer directly against an ordinary negative coefficient trimmer, you can produce a total positive coefficient value that compensates for the actual negative coefficient of the rest of your LC circuit.

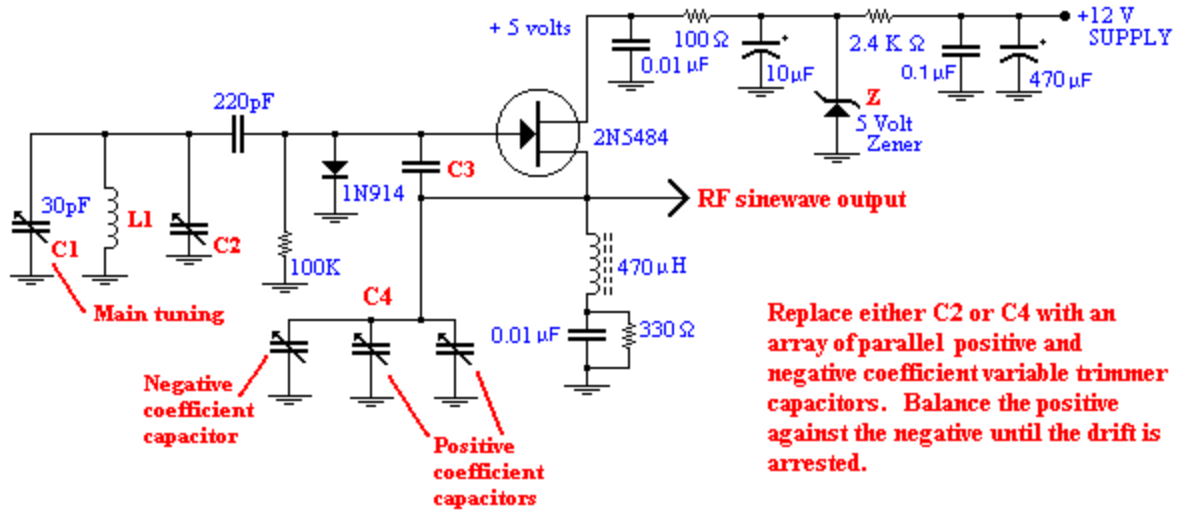

POSITIVE TEMPERATURE COEFFICIENT COMPENSATION

Adjusting VFO temperature compensation

Put a 500 ohm load on the VFO output and put probes across the load for your scope and frequency counter. Check that your voltage supply is set where you want it, say 12.000 volts. It should be rock stable within a millivolt or two. If you're using a mechanical variable capacitor, set the capacitor to maximum capacitance. Now adjust the positive and negative coefficient trimmers to midscale at the desired low-end frequency of the VFO. For example, with a 5 to 5.5 MHz VFO, you would set it to 5.000 MHz (or just below). Check that you can still tune up to 5.5 MHz using the main tuning capacitance. If you can't, you may have to change C3, or fiddle with C4 or C2. Remember that C2 can also be a positive or negative coefficient trimmer, depending on what you need.

Now put the lid on the box but don't screw it down. Watch the frequency drift on your frequency counter. You will almost certainly see it ***drift relentlessly up or down***. If it is going down, assume this is caused by increasing temperature in the box. Turn a positive trimmer to *LESS* capacitance, then adjust a negative trimmer to restore the frequency back to where you started. Repeat this again and again until the drift direction reverses. Now it should be going relentlessly *UP*. Now take off just a bit of the negative trimmer until the drift comes to a halt. When you get them balanced well, the frequency will still change, but now it will ***wander up and down but soon return to the same frequency***. That is, the frequency will no longer march continuously in the same direction. When you get to this point, you have done as well as you can with your present set of components. With luck, during any given minute it won't wander up or down more than 5 Hz.

Thermistor temperature compensation

You may find that your positive trimmer capacitance compensator just doesn't give you enough positive compensation to do a good job. A ***thermistor*** compensation circuit may be just what you need. I had good results with the ARRL handbook circuit below.

Temperature Compensated VFO Thermistor / varactor method

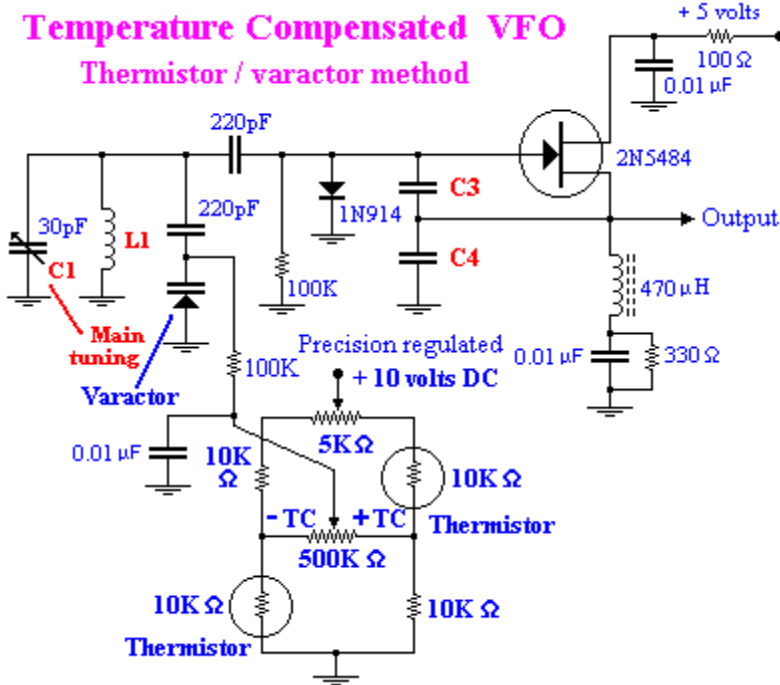

adjusting the 5K and 500K trimmer pots at the top and middle, the degree and direction of the compensation can be selected. Tuning the 500K pot to the right selects more positive compensation. Tuning to the left selects less positive compensation or even negative compensation. If you need more capacitance, you can always parallel two (or more) varactors.

Temperature regulation

Another approach to temperature compensation is to hold the temperature constant by heating the VFO and regulating the temperature with a thermostat. I built such a device inside the lid of my cast metal box. The heater had a resistive heater element and a thermistor-controlled temperature regulation feedback system. The good news was that it regulated the box temperature to within 0.1 degree Fahrenheit. The bad news was that it took the temperature at least 30 minutes to stabilize and, when installed in the transmitter, the regulator was trying to heat the entire transmitter and perhaps the whole room. In other words, a heated VFO box will need extensive thermal insulation in order to be practical. I gave up on this idea.

Resistors are usually designed to change as little as possible with temperature. However thermistors are resistors made from semiconductor that has a large temperature coefficient. The coefficient can either be positive or negative, and both kinds can be used in the above circuit. The thermistors are placed in a bridge circuit with a thermistor on each side of the bridge. The entire circuit is powered by a precision regulated supply, 5 to 10 volts. By

In conclusion,

Precision voltage regulation, temperature compensation and careful adjustment can produce a homebuilt VFO that doesn't drift like a homebuilt. When you get on the air and describe your rig as "all homebrew," the stations you work will (sometimes) shower you with praise. Enjoy every compliment. If you needed as many prototypes as I did to develop a reasonably good VFO, you deserve kudos. Actually, the best complements I've had were when I yacked with guys for an hour without any complaints about my drift. This was especially true if I was able to avoid discussing my funky homebrew transmitter. For all they knew, I was using a first rate modern transceiver.